

A Closer Look at Vertical Antennas With Elevated Ground Systems

N6LF shares his results from more vertical antenna experiments.

[This article is being published in two parts. — Ed.]

Among amateurs, there has been a long running discussion regarding the effectiveness of a vertical antenna with an elevated ground system compared to one using a large number of radials either buried or lying on the ground surface. NEC modeling has indicated that an antenna with four elevated $\lambda/4$ radials would be as efficient as one with 60 or more $\lambda/4$ ground based radials. Over the years there have been a number of attempts to confirm or refute the NEC prediction experimentally, with mixed results. These conflicting results prompted me to conduct a series of experiments directly comparing verticals with the two types of ground systems. The results of my experiments were reported in a series of *QEX*¹⁻⁷ and *QST*⁸ articles (Adobe Acrobat .pdf files of these articles are posted at www.antennasbyn6lf.com). From these experiments I concluded that at least under *ideal* conditions four elevated $\lambda/4$ radials could be equivalent to a large number of radials on the ground.

Confirmation of the NEC predictions was very satisfying but that work *must not be taken uncritically!* My articles on that work failed to emphasize how prone to asymmetric radial currents and degraded performance the 4-radial elevated system is. You cannot just throw up any four radials and get the expected results! I'm by no means the first to point out that the performance of a vertical with only a few radials is sensitive to even modest asymmetries in the radial fan.⁹^{10, 11} It is also sensitive to the presence of nearby conductors or even variations in the soil under the fan.¹² These can cause signifi-

cant changes in the resonant frequency, the feed point impedance, the radiation pattern and the radiation efficiency. While these problems have been pointed out before, as far as I can tell no detailed follow-up has been published. Besides the practical problem of construction asymmetries, at many locations it's simply not possible to build an ideal elevated system even if you wanted to. There may not be enough space or there may be obstacles preventing the placement of radials in some areas or other limitations. I think it's very possible that some of the conflicting results from earlier experiments may

well have been due to pattern distortion and increased ground loss that the simple 4-wire elevated system is susceptible to.

As the sensitivity of the 4-radial system and its consequences sank into my consciousness I began to strongly recommend that people use at least 10 to 12 or more radials in elevated systems. Although I have heard anecdotal accounts of significant improvements in antenna performance when the radial numbers were increased to 12 or more, I have not seen any detailed justification for that. What follows is my justification for my current advice.

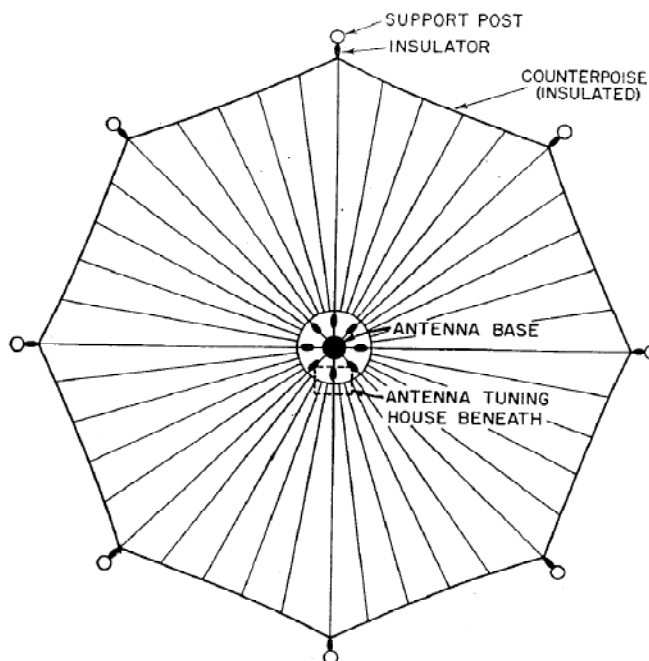

Figure 1 — A typical counterpoise ground system. Figure adapted from Laport.¹⁴

¹Notes appear on page 41

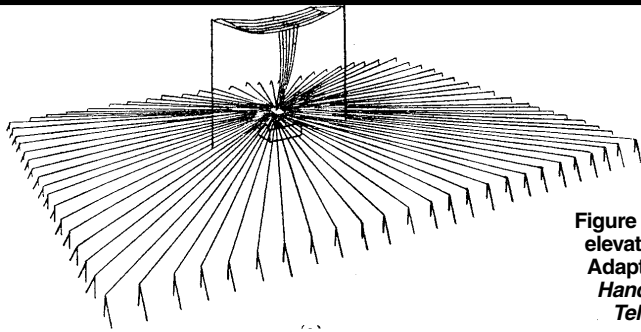

Figure 2 — A very large LF elevated ground system. Adapted from *Admiralty Handbook of Wireless Telegraphy*, 1932.³⁴

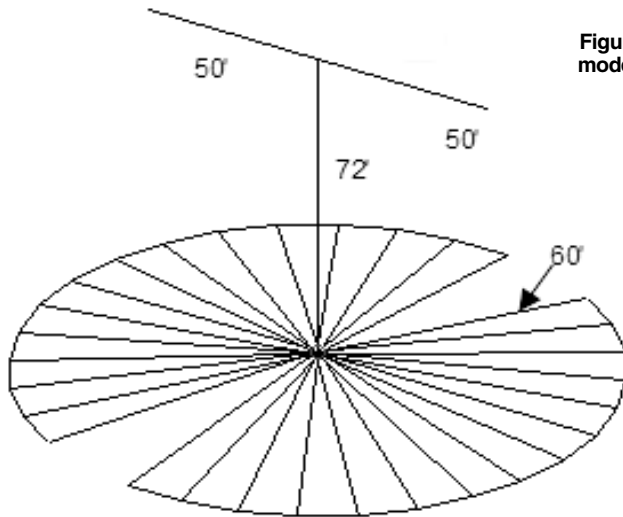

Figure 3 — EZNEC model of the 1BCG antenna.

My original intention for this article was to illustrate the problems introduced by radial fan asymmetries and to discuss some possible remedies. In the process, however, I came to realize that before going into the effects and cures for asymmetries it was necessary to first understand the behavior of ideal systems. Ideal systems can show us when and why they are sensitive and point the way towards possible cures or at least ways minimize problems. The discussion of ideal antennas (over real ground however!) also illustrates a number of subtleties in the design and possibly useful variations that differ somewhat from current conventions.

For these reasons, after some historical examples of elevated wire ground systems, I'll spend a lot of time analyzing ideal systems and then move on to the original purpose of this article: asymmetric radial currents and how to avoid them. At the end of this article I summarize my advice for verticals using elevated ground systems. While much of what follows is derived from NEC modeling, I have incorporated as much experimental data as I could find and compared it to the NEC predictions to see if NEC corresponds to reality.

Prior Work on Elevated Ground Systems

There is a lot of prior information on elevated ground systems: Moxon,^{10,11} Shanney,¹³ Laport,¹⁴ Doty, Frey and Mills,¹² Weber,⁹ Burke and Miller,^{15, 16} Christman,^{18 to 33} Belrose^{39, 42} and many others. There is also my own work, some published but most not.

Some History

In the early days of radio, operating wavelengths were in the hundreds or thousands of meters. Ground systems with $\lambda_0/4$ radials were rarely practical but very early it was recognized that an elevated system called a "counterpoise" or "capacitive ground," with dimensions significantly smaller than $\lambda_0/4$, could be quite efficient. Note, λ_0 is the free space wavelength at the frequency of interest. Figure 1 shows a typical example of a counterpoise.

Here is an interesting quotation from *Radio Antenna Engineering* by Edmund Laport¹⁴ regarding counterpoises:

"From the earliest days of radio the merits of the counterpoise as a low-loss ground system have been recognized because of the way in that the current densities in the ground are more or less uniformly distributed over the area of the counterpoise. It is inconvenient structurally to use very extensive counterpoise systems, and this is the principle reason that has limited their application. The size of the counterpoise depends upon the frequency. It should have sufficient capacitance to have

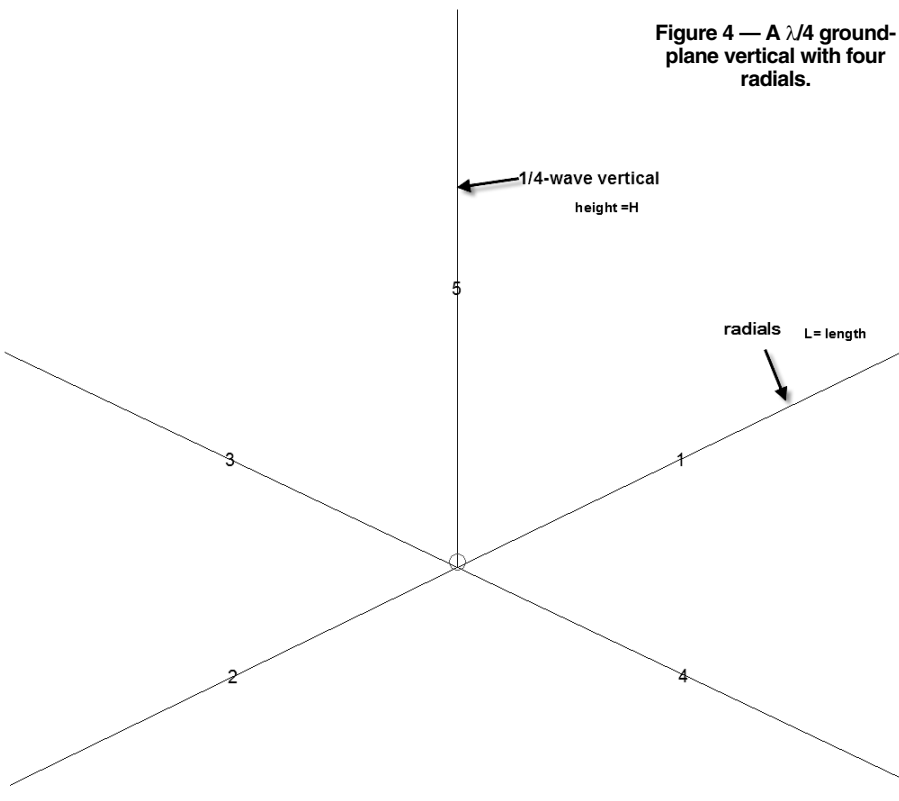

Figure 4 — A $\lambda/4$ ground-plane vertical with four radials.

a relatively low reactance at the working frequency so as to minimize the counterpoise potentials with respect to ground. The potential existing on the counterpoise may be a physical hazard that may also be objectionable.”

Laport was referring to counterpoises that were smaller than $\lambda_0/4$ in radius. In situations where $\lambda_0/4$ elevated radials are not possible amateurs may be able to use counterpoises instead. Unfortunately, beyond the brief remarks made here, I have to defer further discussion of counterpoises to a subsequent article.

Rectangular counterpoises, some with a coarse rectangular mesh, were also common. A rather grand radial-wire counterpoise is illustrated in Figure 2.

Amateurs also used counterpoises. Figure 3 is a sketch of the antenna used for the initial transatlantic tests by amateurs (IBCG) in 1921-22.^{35, 36} The operating frequency for the tests was about 1.3 MHz (230 m). At 1.3 MHz, $\lambda_0/4 = 189$ feet, so the 60 foot radius of the counterpoise corresponds to $\approx 0.08 \lambda_0$.

Note that in all these examples, a large number of radials are used. The use of only a few radials, initially with VHF antennas elevated well above ground, seems to have started with the work of Ponte³⁷ and Brown.³⁸

Behavior With Ideal Radial Fans

In this section we'll look at verticals with a length (H) $\approx \lambda_0/4$ (λ_0 is the free space wavelength) and symmetric elevated radial systems where the height above ground (J) and the number (N) and length (L) of the radials is varied. We'll also look at the effect of soils with different characteristics from poor to very good. Even though we will be looking at verticals with $H \approx \lambda_0/4$, keep in mind that elevated ground systems can also be used with verticals of other lengths, with or without loading, inverted Ls, and other antenna types. Elevated radials can also be used with multi-band antennas.

NEC Modeling

Figure 4 shows a typical model of a vertical with a radial system. Except as noted, the following discussion will focus on operation on 3.5 to 3.8 or 7.0 to 7.3 MHz as the operating band and 3.65 or 7.2 MHz as a spot frequency near mid-band. The conductors (both the vertical and the radials) are lossless no. 12 wire. Most of the modeling was done over real grounds. The modeling used *EZNEC* Pro4 v.5.0.45, using the *NEC4D* engine. The use of *NEC4D* over real soils gives the correct interaction between ground and the antenna. Excellent free programs based on *NEC2* are available, but these do not properly model the ground-antenna interaction, so

that results obtained from them must be used with some caution.⁴¹ For HF verticals close to ground this is an important limitation.

The Effect of Element Dimensions on Performance

The simplest idea of a ground-plane

antenna is that you take a quarter-wave vertical and add four quarter-wave radials at the base. It is well known that the elements of a dipole will be a few percent shorter than λ_0 so it is usually assumed that in a ground-plane antenna the vertical and the radial lengths will also be a few percent less than λ_0 . Typically

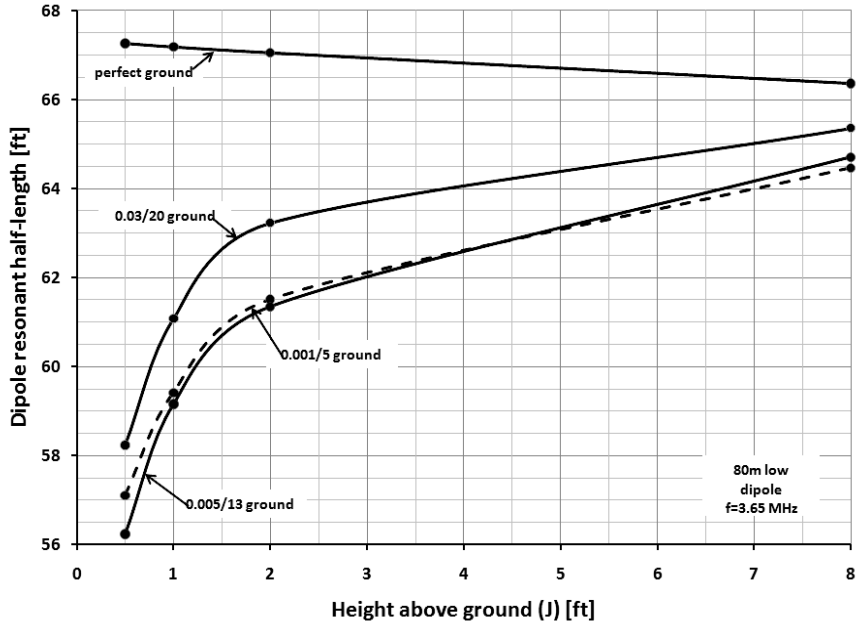

Figure 5 — Dipole half-length for resonance for different values of J and different soils.

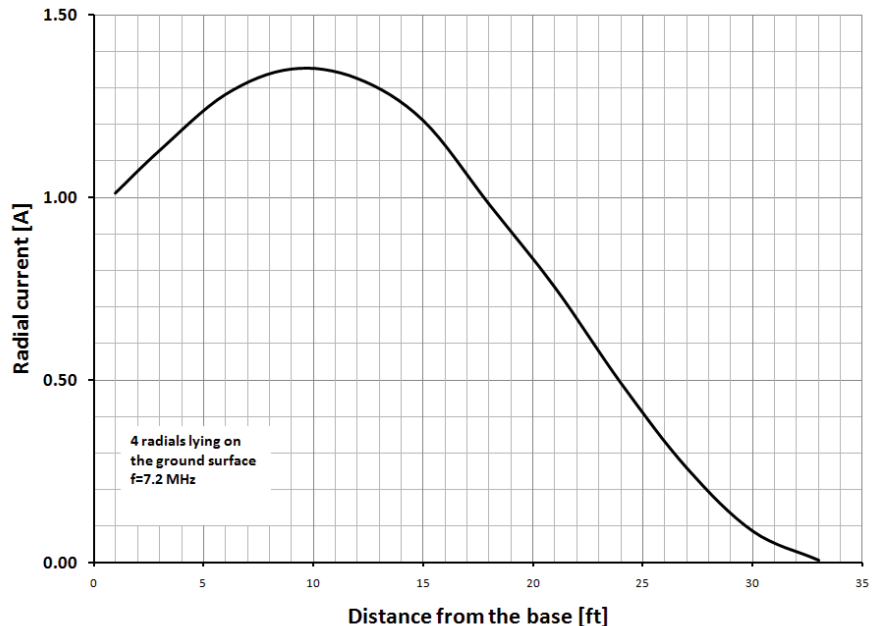

Figure 6 — Measured current on a 33 foot radial at 7.2 MHz. This antenna uses four radials lying on the ground surface.

it is assumed that the vertical and the radials will be *individually* resonant at the operating frequency. Unfortunately it's not that simple, because the vertical is coupled to the radials and both interact strongly with ground because, at least at lower HF (<20 m), the base of the vertical and radial fan will usually be only a fraction of λ_0 above ground. What you have in reality is a coupled multi-tuned system with complicated interactions. It turns out that there are a wide range of pairs of values for H and L that result in resonance, or $X_{in} = 0$ at the feed point (where $Z_{in} = R_{in} + j X_{in}$ and Z_{in} is the feed point impedance). Some of these combinations where neither the vertical nor the radials are individually resonant may be useful.

Antenna Resonance and Element Dimensions

The free space wavelength (λ_0) at a given frequency in MHz (f_{MHz}) is given as:

$$\lambda_0 = \frac{299.792}{f_{MHz}} [m] = \frac{983.570}{f_{MHz}} [feet] \quad [Eq 1]$$

At 3.65 MHz, $\lambda_0/4 = 67.368$ feet. If we model a resonant $\lambda/4$ vertical over perfect ground using no. 12 wire, we find that at 3.65 MHz, $\lambda/4 = H = 65.663$ feet, which is about 3.5% shorter than $\lambda_0/4$.

To take into account the effect of ground on radial resonance for a given value of J and soil characteristic, it has been suggested that we can erect a low dipole at the desired radial height (J) and trim its length to resonance. An example of this is given in Figure 5.

For J = 8 feet, depending on the soil, L varies from 64.5 feet to 66.4 feet. As we reduce J we find that L gets smaller. The shift in resonance for radials close to ground has also been demonstrated experimentally. (See Note 2.) Figure 6 shows the measured radial current at 7.2 MHz on 33 foot radials (sum of four radials). Clearly this radial is $\lambda/4$ resonant at a lower frequency than 7.2 MHz! As Figures 5 and 6 show, the effect gets much larger for small values of J.

What do we mean by "resonant" values for H and L "independently"? It's not just that the reactances cancel at the feed point. When I say "the resonant length for H or L" I'm talking about the case where the current distribution on the vertical and the radials independently corresponds to resonance: in other words, the current just reaches a maximum at either the base of the vertical or at the inner ends of the radials. If either H or L is made longer than resonance, the current maximum will move out onto the radials or up the vertical. Figure 7 shows the current distribution on a vertical and the radials for three combinations of H and L, each of which yield $X_{in} = 0$ at the feed point.

To better understand what's happening we can expand Figure 7 around the 1 A feed point (indicated by the arrow) as shown in Figure 8.

For H = 64 feet and L = 80.85 feet, the current on the vertical has not peaked so the vertical is too short for resonance. The radial current peak is well out on the radials, however, so clearly the radials are too long for

resonance. The reactance of the vertical and the radials cancels at the feed point so the antenna is "resonant" but not the vertical and radials individually. Similarly, for H = 69 feet and L = 58.8 feet, the current in the vertical peaks and begins to fall (moving from the top to the bottom of the vertical) before the feed point is reached. Again, we have a resonant antenna but the vertical and the radials are not

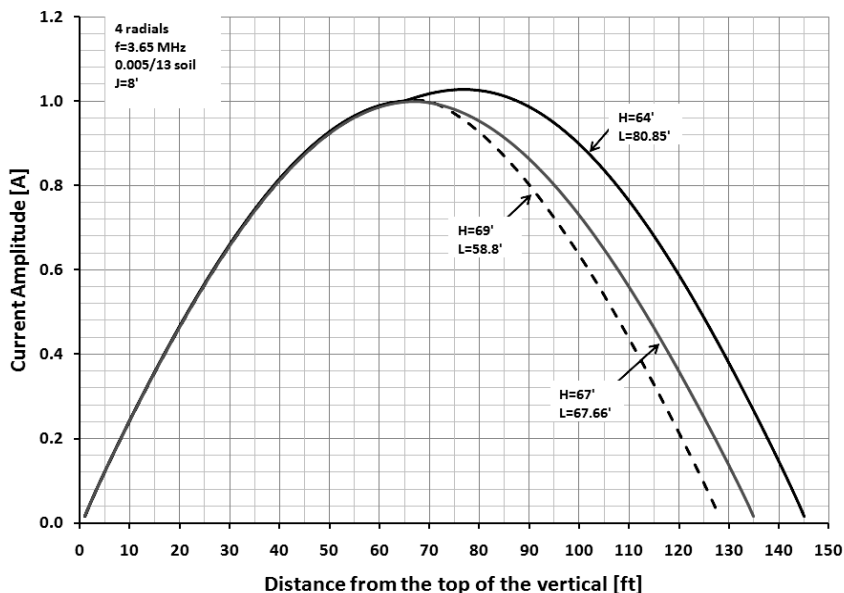

Figure 7 — Current distribution on the vertical and the radials. The current starts at the top of the vertical, runs to the base and then out along the radials. The radial current is the sum of the currents in the four radials. The currents are for 1 A_{ms} at the feed point.

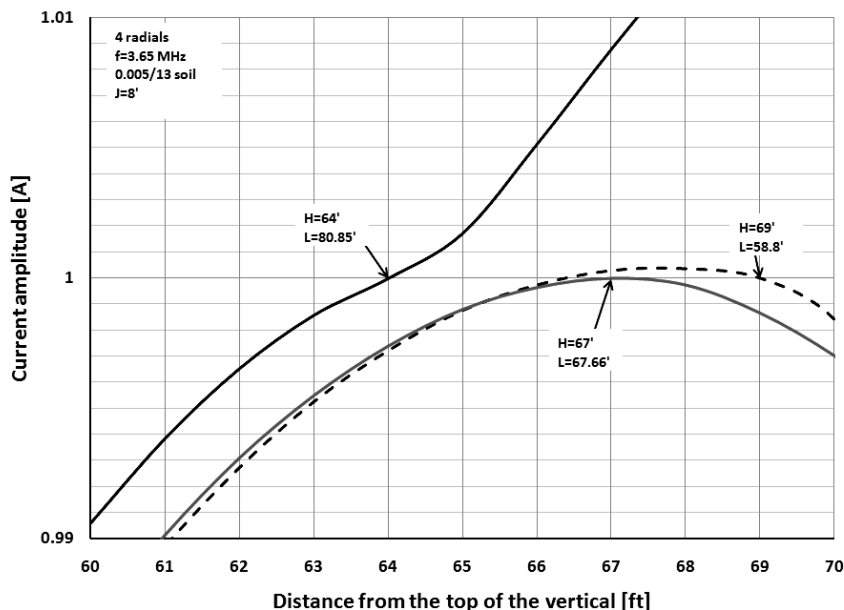

Figure 8 — Current distribution on the vertical and the radials expanded around the feed point. The arrows point to the junctions between the vertical and the radials.

individually resonant. If we set $H = 67$ feet and $L = 67.66$ feet, however, both the vertical and the radials are $\lambda/4$ resonant individually.

The “resonant length” (by the definition given above!) of the vertical is 67 feet and the “resonant” length for the radials is 67.7 feet, both of these lengths are substantially different than the value we got earlier for $\lambda/4$ resonance for a vertical over an infinite perfect ground-plane (65.7 feet). The “resonant” radial length of 67.7 feet is quite different from the dipole 8 feet above average ground (64.7 feet). H and L are actually closest to λ_0 (67.4 feet). What we have just seen is only one particular example. If we change J and/or the soil characteristics and/or the number of radials, these lengths will change!

Setting up the antenna so that both the vertical and the radials are individually resonant turns out to not be so simple and we might ask, “Is it really necessary to have both the vertical and the radials resonant individually?” It turns out that there are other considerations besides the current distribution with regard to the choice of L for a given H . It is possible to use values of L where $X_{in} \neq 0$ and compensate for that with a tuning impedance at the feed point for example, or perhaps use some top-loading. In addition, in some situations it may not be possible to have radials long enough to make $X_{in} = 0$ while keeping the radial fan symmetric. Further, Weber has suggested that radials with $L < \lambda/4$ or $> \lambda/4$ are a possible cure for radial current division inequality. (See Note 9.) So we have reasons to investigate the effect of variations in vertical height and radial length on antenna behavior.

For each value of H , number of radials (N), height above ground (J), ground characteristic ($\sigma =$ conductivity and $\epsilon_r =$ permittivity) and choice of operating frequency, there will be some radial length (L_r) that makes the antenna resonant. That’s a lot of variables! So we will look at only a few examples to get a general idea of what happens.

Figure 9 gives an example of the variation in the value for L_r that results in resonance at the feed point ($X_{in} = 0$) as a function of N and several values of H , with fixed values of f , J and soil.

Notice how widely L_r varies with N for most values of H although there is one value for H (66.71 feet) that seems to have only a small variation in L_r as N is changed. Note also how much shorter L_r becomes when H is increased by a few feet. This could be very useful in situations where space for the radial fan is limited. On the other hand note how quickly L_r grows when H is shortened. For $N = 16$ we see that when $H = 64$ feet, $L_r = 106$ feet but for $H = 69$ feet, L_r is only 39 feet! That’s a difference in L_r of almost 3:1. If you cannot make H long enough, all is not lost! A bit of top loading has an effect much like increasing H .

Another way to explore the interaction between L and N is to set L equal to L_r for some value of N (say 16 radials) and while watching the resonant frequency (f_r), vary the number of radials as shown in Figure 10. Note that the most stable f_r is where $H = L = 66.71$ feet. That is relatively close to the values we got earlier for independently resonant vertical and radials. (Be careful, this is particular to this example; things will vary with

different J , ground type, and other variables). Note also that for H a bit tall, f_r decreases as radials are added, but if H is a bit short f_r increases as radials are added. This kind of behavior can be confusing if you are trimming the radials to resonate at a particular frequency, especially if you add some radials. It is possible you could add some radials and then have to make all the original radials longer!

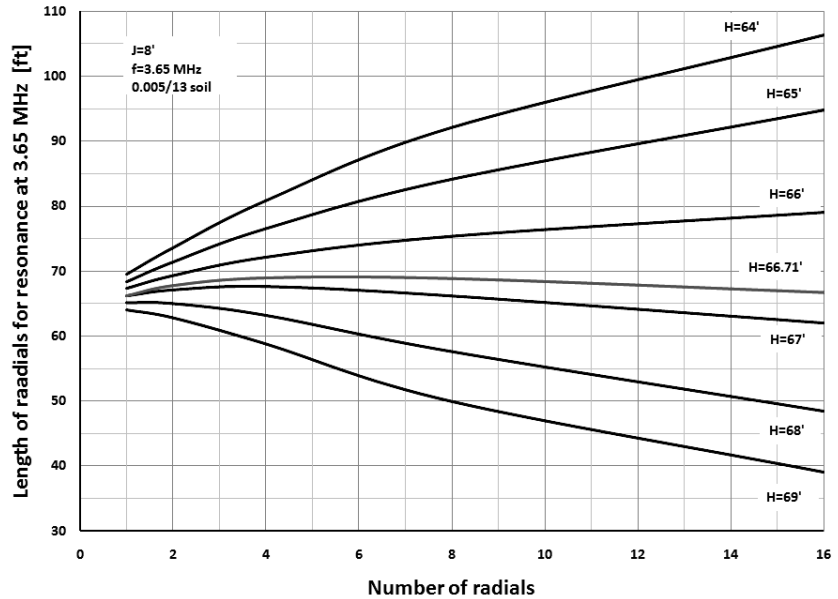

Figure 9 — Examples of the effect of radial number on the radial length for resonance at 3.650 MHz (L_r) for several different values of H .

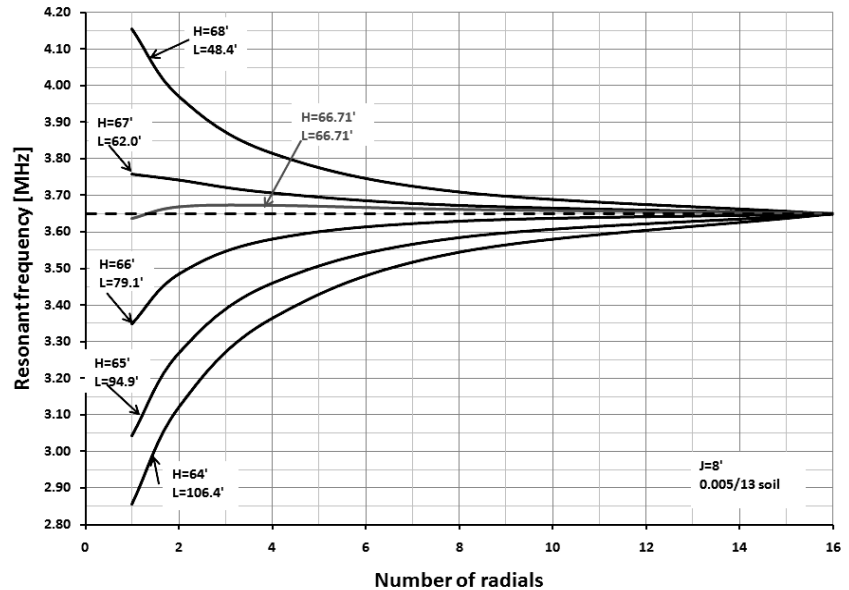

Figure 10 — Resonant frequency of the antenna as a function of radial number for several combinations of H and L that are resonant at 3.650 MHz with $N = 16$.

This raises the question, “Do real antennas actually behave this way?” During the ground system experiments, I saw exactly this kind of behavior. For the 160 m vertical, f_r went down as I added radials but for the 40 m verticals, f_r went up with radial number. Figure 11 shows graphs of experimental measurements, one for 160 m and the other for 40 m. Real antennas can behave as the modeling predicts.

At this point it’s pretty clear that there is considerable interaction between the variables (H, L, J, and so on) but it’s not obvious yet if there are optimum combinations (some better than others).

The effect of radial length on efficiency

It turns out that the values for both N and L can have a significant effect on the efficiency of the antenna. Burke and Miller published a very interesting paper in 1989 with the results of NEC modeling of both elevated and buried radial systems for a wide range of N, L, J and soil characteristics.¹⁵ I read this paper many years ago but I have to admit that it did not dawn on me just how much important information was there. Recently the light dawned as I re-read the paper and some additional graphs that Jerry Burke kindly sent me, so I have been redoing some of their modeling. Some of the Burke-Miller graphs were plots of average gain (G_a) versus radial length with radial number as a parameter. G_a is a useful proxy for radiation efficiency in that it gives the proportion of the input power to the antenna that is actually radiated into space. G_a is the ratio of the radiated power (P_r) to the input power (P_{in}) in dB ($G_a = 10 \text{ Log } [P_r/P_{in}]$). All of the power dissipated in the earth, including the near-field losses and reflections in the far-field, are subtracted from the input power. What is actually done is to integrate the power flow across a hemisphere with a very large radius centered on the antenna. The total power flowing through the surface of the hemisphere is P_r . I should emphasize that this is the power radiated towards the ionosphere, power in the ground-wave is considered a loss. For Amateurs, where sky-wave propagation is the norm at HF, this makes sense.

The Burke-Miller graphs used a constant value for H. I will begin with similar graphs but for Amateurs it is more likely that as L is increased H will be decreased to maintain resonance at a given frequency, so I will also show that variation.

Figure 12 is an example of the effect of radial length and radial number on G_a of the antenna when H is kept constant (68 feet in this example).

Figure 12 has some interesting features:

1) Beginning with short values for L, G_a increases slowly up to a maximum. Below maximum, using radials somewhat shorter

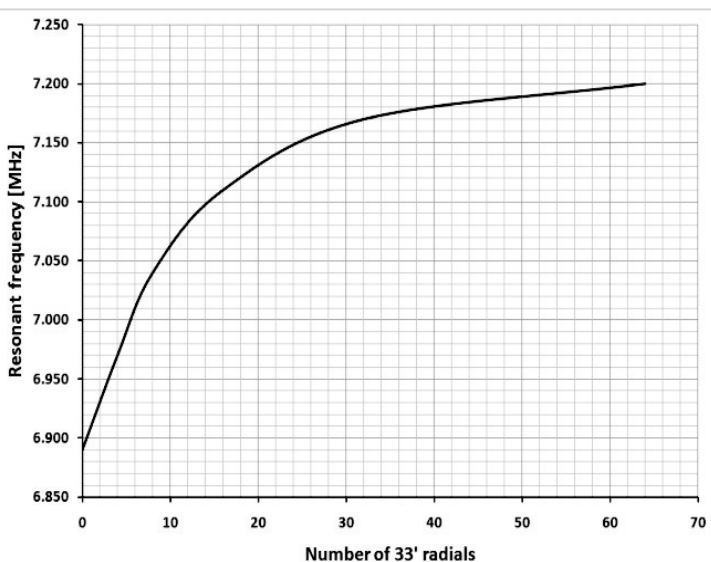
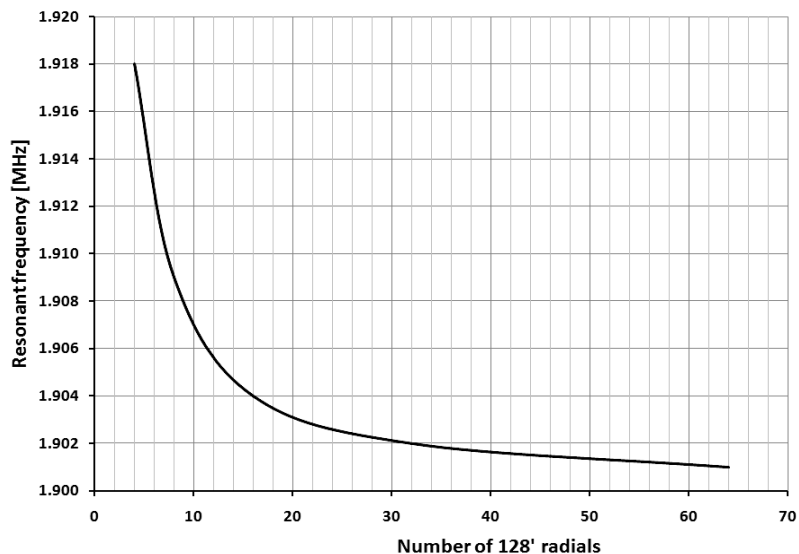

Figure 11 — Experimental measurements of the effect of radial number on resonant frequency.

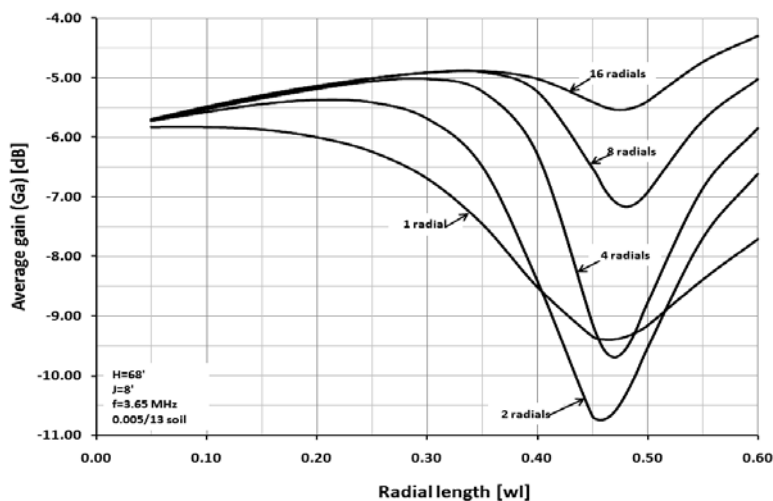

Figure 12 — Average gain as a function of radial length (in wavelengths, λ_0) and number of radials. H = 68 feet, J = 8 feet, f = 3.650 MHz and 0.005/13 soil.

than $\lambda/4$ does not seriously reduce the efficiency.

2) Above the maximum, however, there is a large dip! The bottom of the dip can be as much as -7 dB before G_a rises again for longer lengths.

3) Up to the length where G_a starts to fall, increasing N doesn't make much difference in G_a as long as you have four or more radials, but increasing N does push the dip towards longer radial lengths and reduces the depth of the dip.

Figure 12 is for the case where $J = 8$ feet. If we reduce J , the G_a graphs will change, as illustrated in Figure 13.

As the antenna is moved closer to ground, the efficiency starts to fall, the maximum is lower and the dip gets deeper and occurs at shorter values of L . In fact, if you push J down to 1 inch or less (the case for radials lying on the ground surface) the notch gets even deeper and begins to fall off at lengths well below $\lambda_0/4$. Note, however, that the effect is substantially reduced when larger numbers of radials are used.

One of the suggestions for improving current division between radials was to make them substantially longer than $\lambda_0/4$, in other words, $L = 3 \lambda_0/8$. (See Note 9.) As Figures 12 and 13 show, that's probably not a good idea unless you're using 16 or more radials, but with that many radials current division will already be much improved, as we'll see shortly. Before getting carried away with conclusions we have to ask, "Do real antennas actually behave this way and do we have any experimental verification?" As part of the ground system experiments reported in *QEX* and *QST* (see Notes 1 to 8), I measured the signal strength as N and L were varied with H constant. Figure 14 is a typical result.

I have to admit that during the experiments I did not make the connection between my measurements and the work of Burke and Miller (see Note 15) so I only extended the radial lengths out to slightly less than $\lambda_0/4$. But we can still see the predicted behavior:

- 1) For short L , the gain rises slowly to a point where it starts to fall.
- 2) When L is large the dip in gain is large.
- 3) Increasing N reduces the dip and moves it to larger values for L .

Besides the data shown in Figure 14, I ran spot checks on the gain with sixteen and thirty two 33 foot radials. These were also in agreement with the NEC predictions. I think it's pretty clear that NEC is telling us the truth and we need to pay attention! Radial length is an important consideration.

Figures 12 and 13 are for $\sigma = 0.005$ S/m and $\epsilon_r = 13$, Figure 15 shows the effect of different soil characteristics on G_a for given H , J and N .

As we saw in Figure 6, close proximity

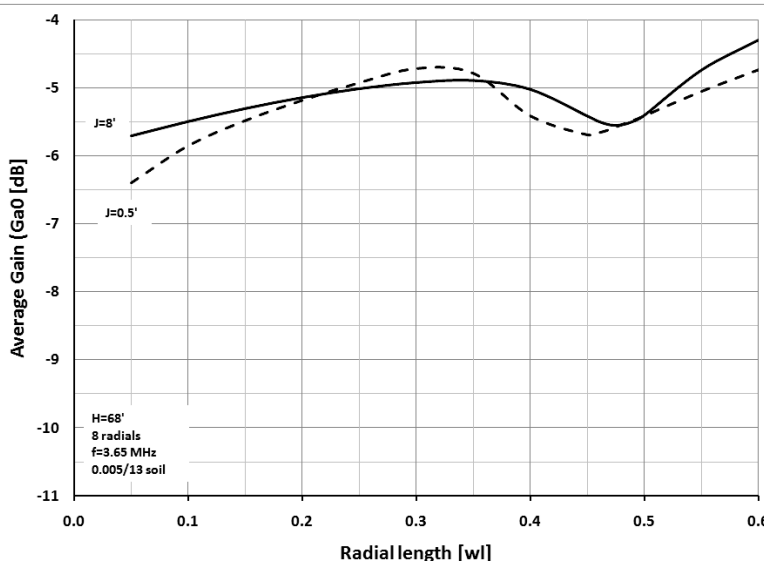
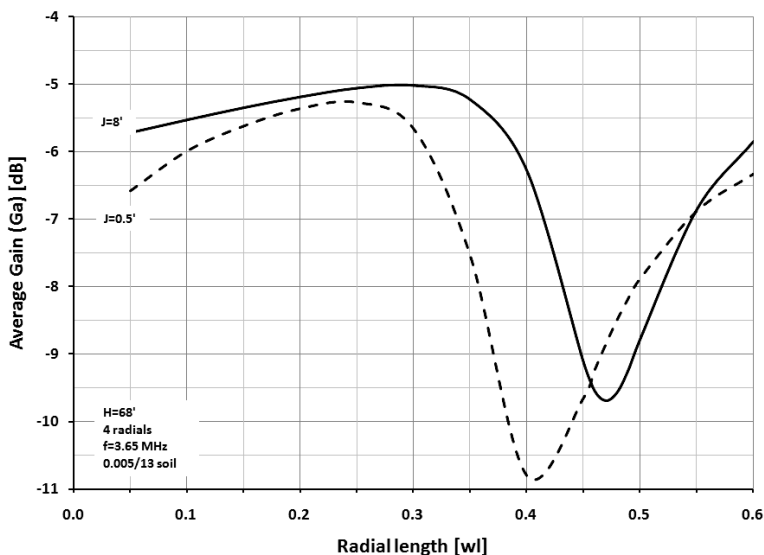

Figure 13 — Comparison of G_a for $J = 8$ feet and 0.5 feet. $N = 4$ and 8, and L is in $\lambda_0 = wl$.

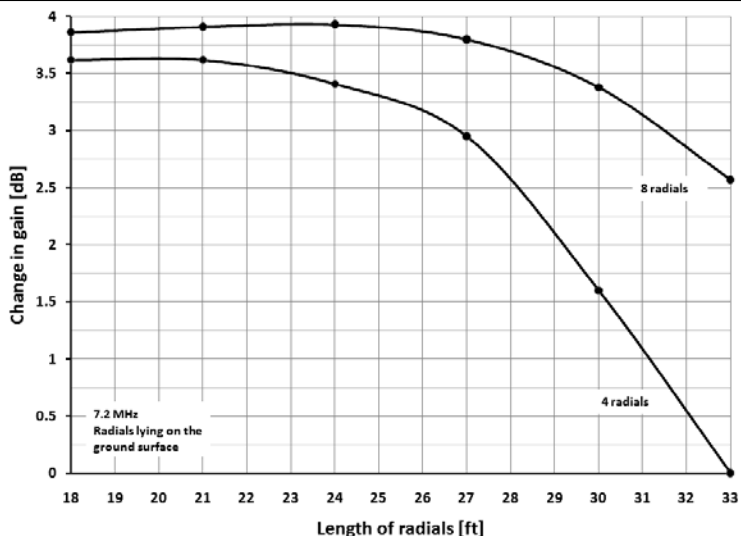

Figure 14 — Far-field change in signal strength as L and N are varied. Radials are lying on the ground surface. $f = 7.2$ MHz.

to ground has great effect on the radial resonant frequency. John Belrose, VE2CV, has modeled G_a for radials lying close to ground and the effect of different numbers of radials as shown in Figure 16.⁴² Note that the data points in the graph were taken from Belrose's article and re-graphed.

The dashed line in Figure 16 represents the case where the lengths of the four radials are adjusted so that the radials are resonant. The predictions in Figure 16 agree with the experimental work shown in Figure 14 showing the effect of shortening the length of radials close to ground. Figure 16 also predicts that even a very small increase in height above ground for the radials will make a large difference in loss, especially if N is small. This large change in G_a with small elevations has been verified experimentally (see Note 3) as shown in Figure 17.

In some cases it may be necessary to use a vertical with H other than $\lambda/4$. Figure 18 shows G_a as a function of L for $H = 100$ feet ($\approx 3 \lambda_0/8$), $H = 68$ feet ($\approx \lambda_0/4$) and $H = 34$ feet ($\approx \lambda_0/8$) with and without top-loading. Compared to $H = 68$ feet, the notch for $H = 34$ feet begins a lower value of L and is much deeper. Putting a short base loaded vertical over an elevated ground-plane may not be a good idea. (Note: this is something that needs to be explored further!) If we add two horizontal top-loading wires that restore the resonance of the 34 foot wire to that of the 68 foot wire, G_a is greatly improved. With the top-loaded vertical, the peak value for G_a is a few tenths of a dB lower than for the full height vertical but that may be acceptable because the vertical is only half as tall. That's something to think about for 160 m verticals. It is also interesting to note that the taller vertical ($H \approx 3\lambda/8$) while more tolerant of longer radials is somewhat less efficient (≈ -0.5 dB). The lesson to draw here is that using elevated ground systems with short verticals can be problematic but really tall verticals may not be all that great either. You have to model the specific situation carefully to make sure you understand what's going on.

The graphs in Figure 12 assume that H is constant. We could also have varied H so that $X_{in} = 0$ for every value of L . This may give us some insight into optimum combinations (with regard to G_a !) of H and L . Figure 19 shows what happens when we do this compared to the case where H was constant for $N = 4$ and 16. The curves for a fixed H (solid lines) and variable H (dashed lines) are very similar, except that for the four radial case, the dip sets in a bit earlier and is somewhat deeper. The maximum G_a point is about $0.28 \lambda_0$ with four radials and about $0.35 \lambda_0$ with sixteen radials, but in both cases the maximum is very broad. As long as you stay

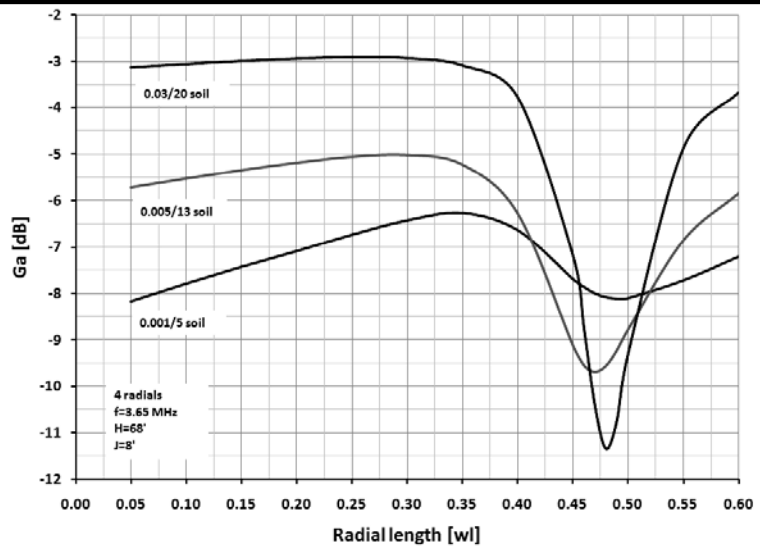

Figure 15 — Effect on G_a of different soils for $H = 68$ feet, $J = 8$ feet and $N = 4$.

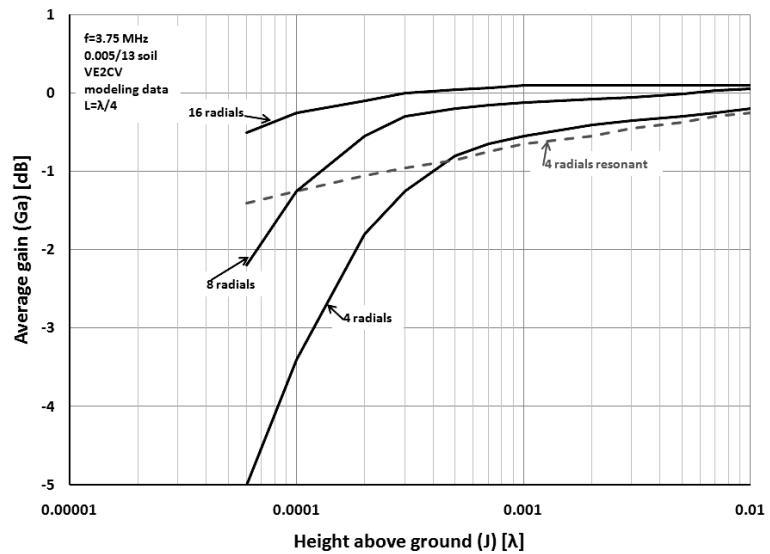

Figure 16 — Average gain when radials are placed close to ground.

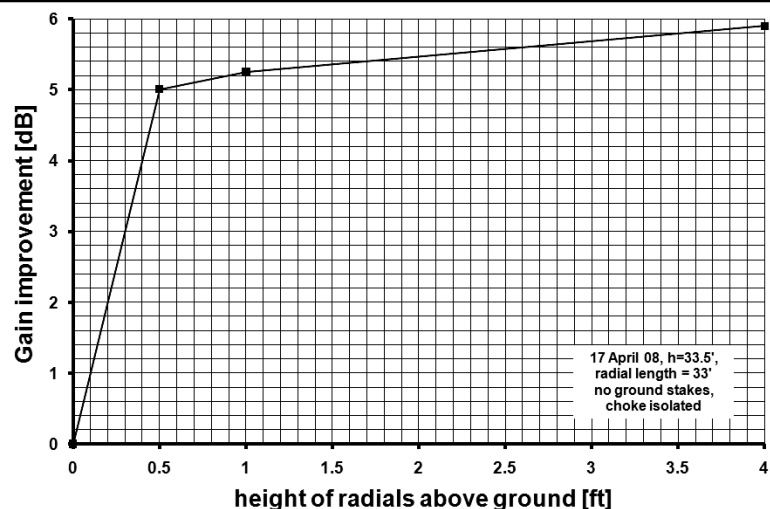

Figure 17 — Measured change in gain as four radials are elevated above ground.

below the point where G_a starts to fall, the value of L is not critical.

Figure 20 shows the values for H that result in resonance at 3.650 MHz for each radial length in Figure 19.

Again we see that the sensitivity to radial length is smaller when more radials are used. We can also look at the effect on R_{in} at resonance as we vary the $H + L$ combination. An example is given in Figure 21.

When four radials are used there is also an important effect on the radiation pattern when the radials are too long.

Figure 22 compares the radiation patterns for two different combinations: $L = 0.29 \lambda_0$ and $L = 0.46 \lambda_0$. The first is close to the peak G_a value and the second is at the minimum of G_a . In the case of the long radials, not only is G_a much smaller but the peak of the radiation pattern has moved from about 22° to 45° ! Clearly if you are using only a few radials, long radials are bad idea.

An Explanation for the Dips in G_a

Why do we see these large dips in G_a for some values of L ? We can investigate this by looking at the current distributions on the radials and the associated E and H-field intensities close to ground under the radials. Figure 23 shows examples of the current distribution on the radials as a function of distance from the base (feed point) for several different radial lengths; 64, 70, 80, 100 and 121 feet. The graphs are for $N = 4$ except for the dashed line, where $N = 16$ and $L = 121$ feet.

For the same current at the feed point, with longer radials the currents are much higher as we go out from the base. We would expect these higher currents to increase both E and H-field intensities at ground level under the radials. Using the near-field plotting capability of NEC we can visualize the field intensities as shown in Figure 24.

Figure 24 shows the drastic increase in field intensities with longer radials. In this case I've chosen the longer radial length (121 feet) to correspond to the dip in G_a in Figure 12. Since the power dissipation in the soil will vary with the square of the field intensity, it's pretty clear why the efficiency takes such a large dip when the radials are too long. Figure 25 illustrates what happens to the fields under the radial fan when more radials are employed.

The earlier quotation from Laport stated that the use of more radials would make the fields under the radial fan more uniform. Figure 25 certainly supports that but we can go one step further to show how much the fields are smoothed with more numerous radials. Figure 26 makes that point.

Figure 26 is the E-field intensity just above ground level at points lying on a 90° arc with a radius of 40 feet (centered on the base) for two radial lengths ($L = 64$ feet and

121 feet) and $N = 4$ and 16. We can see that with only 4 radials, the E-field peaks sharply directly under the radials but with 16 radials the field is much more uniform.

In Part 2

In the second part of this series, we will examine radial systems for multiband verticals. We also take a look at the effect of various asymmetries in the radial fan.

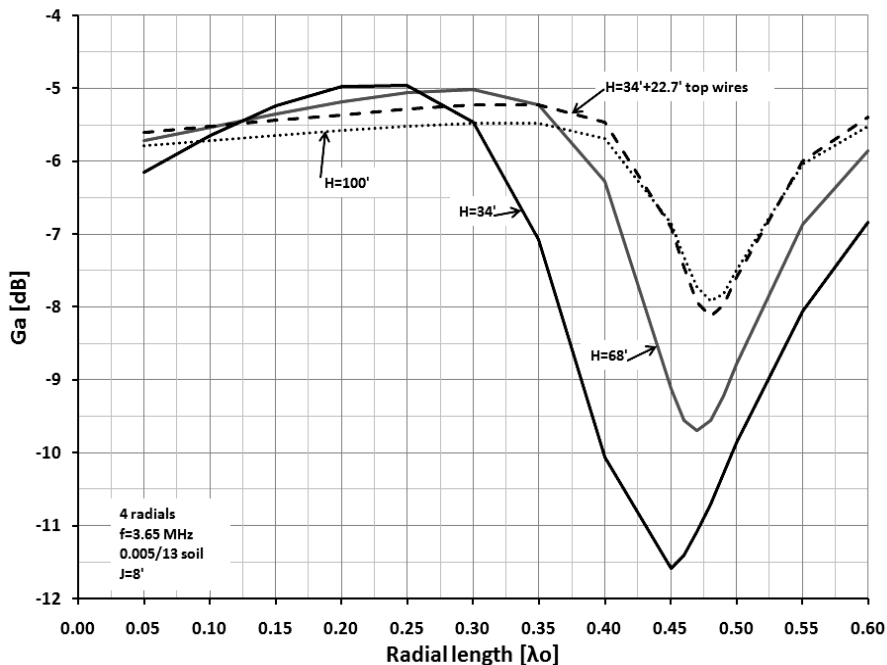

Figure 18 — Effect on G_a of short verticals. $H = 100$ feet, 68 feet, 34 feet and 34 feet with top-loading.

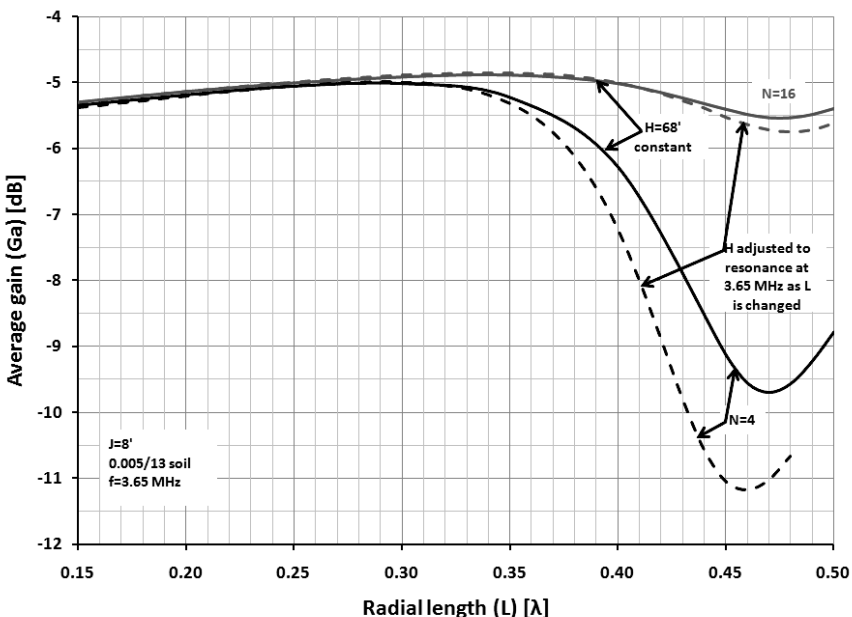

Figure 19 — Effect on G_a of radial length when H is varied to keep $X_{in} = 0$ at 3.650 MHz compared to the case where H is constant at 68 feet (from Figure 12).

Rudy Severns, N6LF, is a retired electrical engineer (UCLA '66). He holds an Amateur Extra class license and was first licensed in 1954 as WN7WAG. He is a life fellow of the IEEE and a live member of the ARRL. His current Amateur Radio interests are antennas, particularly HF vertical arrays and interactions between towers and arrays. He also enjoys 600 m operation as part of the group under the WD2XSH experimental license. Some of his publications about antennas are posted on his website at www.antennasbyn6lf.com.

Notes

¹Severns, Rudy, N6LF, "Experimental Determination of Ground System Performance for HF Verticals, Part 1, Test Setup and Instrumentation," *QEX*, January/February 2009, pp 21-25.

²Severns, Rudy, N6LF, "Experimental Determination of Ground System Performance for HF Verticals, Part 2, Excessive Loss in Sparse Radial Screens," *QEX*, January/February 2009, pp 48-52.

³Severns, Rudy, N6LF, "Experimental Determination of Ground System Performance for HF Verticals, Part 3, Comparisons Between Ground Surface and Elevated Radials," *QEX*, March/April 2009, pp 29-32.

⁴Severns, Rudy, N6LF, "Experimental Determination of Ground System Performance for HF Verticals, Part 4, How Many Radials Does My Vertical Really Need?" *QEX*, May/June 2009, pp 38-42.

⁵Severns, Rudy, N6LF, "Experimental Determination of Ground System Performance for HF Verticals, Part 5, 160 m Vertical Ground System," *QEX*, July/August 2009, pp 15-17.

⁶Severns, Rudy, N6LF, "Experimental Determination of Ground System Performance for HF Verticals, Part 6, Ground Systems for Multi-band Verticals," *QEX*, January/February 2009, pp 19-24.

⁷Severns, Rudy, N6LF, "Experimental Determination of Ground System Performance for HF Verticals, Part 7, Ground Systems with Missing Sectors," *QEX*, January/February 2010, pp 18-19.

⁸Severns, Rudy, N6LF, "An Experimental Look at Ground Systems for HF Verticals," *QST*, Mar 2010, pp 30-33.

⁹Dick Weber, K5IU, "Optimum Elevated Radial Vertical Antennas," *Communication Quarterly*, Spring 1997, pp 9-27.

¹⁰Moxon, Les, G6XN, *HF antennas for All Locations*, 2nd edition, Radio Society of Great Britain, 1993.

¹¹Moxon, Les, G6XN, "Ground Planes, Radial Systems and Asymmetric Dipoles," *ARRL Antenna Compendium*, Vol 3, 1992, pp. 19-27.

¹²Doty, Frey and Mills, "Efficient Ground Systems for Vertical Antennas," *QST*, Feb 1983, pg 20.

¹³Shanney, Bill, KJ6GR, "Understanding Elevated Vertical Antennas," *Communications Quarterly*, Spring 1995, pp 71-76.

¹⁴Laport, Edmund A., *Radio Antenna Engineering*, McGraw-Hill, 1952. Note:

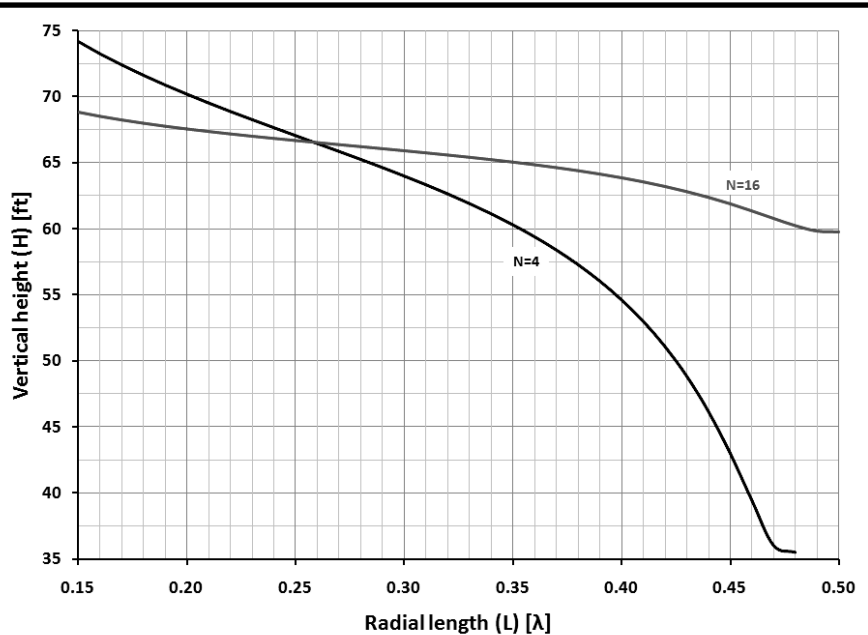

Figure 20 — Values for H that make $X_{in} = 0$ as L is varied.

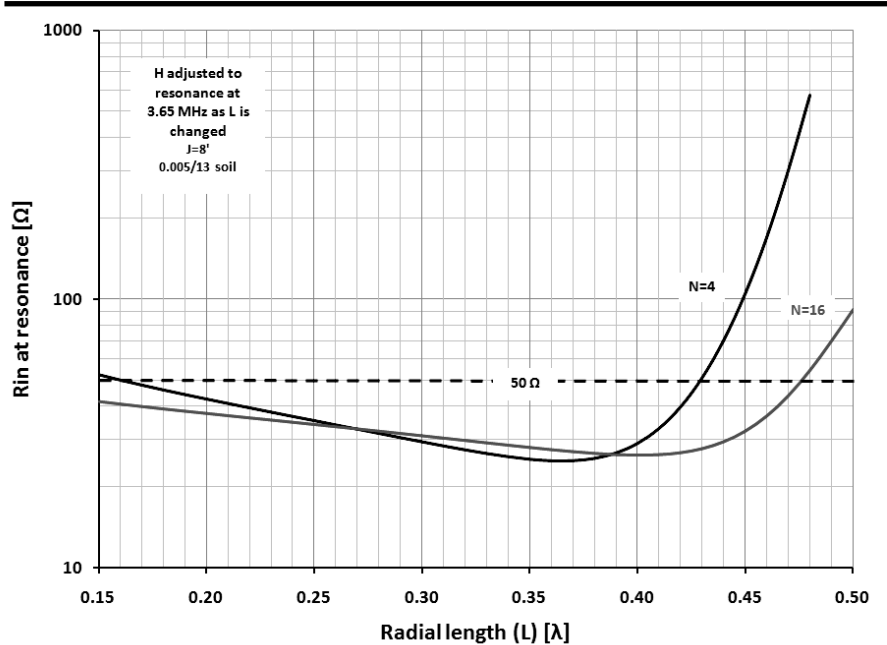

Figure 21 — R_{in} at resonance as a function of L.

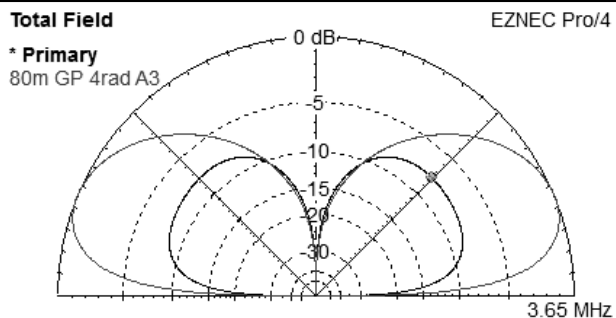

Figure 22 — Radiation pattern for H = 64.64 feet – L = 78.15 feet and H = 39.49 feet – L = 123.96 feet. N = 4 in both cases.

this book is available on-line in .pdf format at <http://snulbug.mtview.ca.us/books/RadioAntennaEngineering/>.

- ¹⁵Burke and Miller, "Numerical Modeling of Monopoles on Radial-wire Ground Screens", *IEEE Antennas and Propagation Society International Symposium Proceedings*, June 1989, pp 244-247.
- ¹⁶Burke, Weiner and Zamosciaynk, "Radiation Efficiency and Input Impedance of Monopole Elements With Radial-Wire Ground Planes in Proximity to Earth," *Electronics Letters*, 30 July 1992, pp 1550-51.
- ¹⁸Christman, AI, K3LC, "Ground Systems for Vertical Antennas," *Ham Radio*, August 1979, pp. 31-33.
- ¹⁹Christman, AI, K3LC, "AM Broadcast Antennas With Elevated Radial Ground Systems," *IEEE Transactions on Broadcasting*, March 1988, Vol 34, No. 1, pp. 75-77
- ²⁰Christman, AI, K3LC, "Elevated Vertical-Antenna Systems", *QST*, August 1988, pp 35-42. Additional comments related to this article, *QST Technical Correspondence*, May 1989, pg.50.
- ²¹Christman and Radcliff, "Impedance Stability and Bandwidth Considerations for Elevated-Radial Antenna Systems," *IEEE Transactions on Broadcasting*, June 1989, Vol 35, No. 2, pp 167-171.
- ²²Christman and Radcliff, "Elevated Vertical Monopole Antennas: Effects of Changes in Radiator Height and Radial Length," *IEEE Transactions on Broadcasting*, December 1990, Vol 36, No. 4, pp 262-269.
- ²³Christman and Radcliff, "Using Elevated Radials With Ground Mounted Towers," *IEEE Transactions on Broadcasting*, September 1991, Vol 37, No. 3, pp 77-82.
- ²⁴Christman, Zeineddin, Radcliff and Breakall, "Using Elevated Radials in conjunction with Deteriorated Buried-Radial Ground Systems," *IEEE Transactions on Broadcasting*, June 1993, Vol 39, No. 2, pp 249-254.
- ²⁵Christman and Radcliff, "AM Broadcast Antennas with Elevated Radials: Varying the Number of Radials and Their Height Above Ground," *IEEE Transactions on Broadcasting*, 1996.
- ²⁶Christman, AI, K3LC, "Elevated Vertical Antennas for the Low Bands: Varying the Height and Number of Radials," *ARRL Antenna Compendium*, Vol 5, 1996, pp 11-18.
- ²⁷Christman, AI, K3LC, "Dual-Mode Elevated Verticals," *ARRL Antenna Compendium*, Vol 6, 1999, pp 30-33.
- ²⁸Christman, AI, K3LC, "Elevated Vertical Antennas Over Sloping Ground," *ARRL Antenna Compendium*, Vol 6, 1999, pp 189-201.
- ²⁹Christman, AI, K3LC, "'Gull-Wing' Vertical Antennas," *National Contest Journal (NCJ)*, Nov 2000, pg 14.
- ³⁰Christman, AI, K3LC, "Using Elevated Radials With Grounded Towers," *IEEE Transactions on Broadcasting*, Vol 47, No. 3, September 2001, pp 292-296.
- ³¹Christman, AI, K3LC, "A Study of Elevated Radial Ground Systems for Vertical Antennas," Part 1, *National Contest Journal (NCJ)*, January/February 2005, pp 19-22. Part 2, *NCJ*, March/April 2005, pp 17-20.

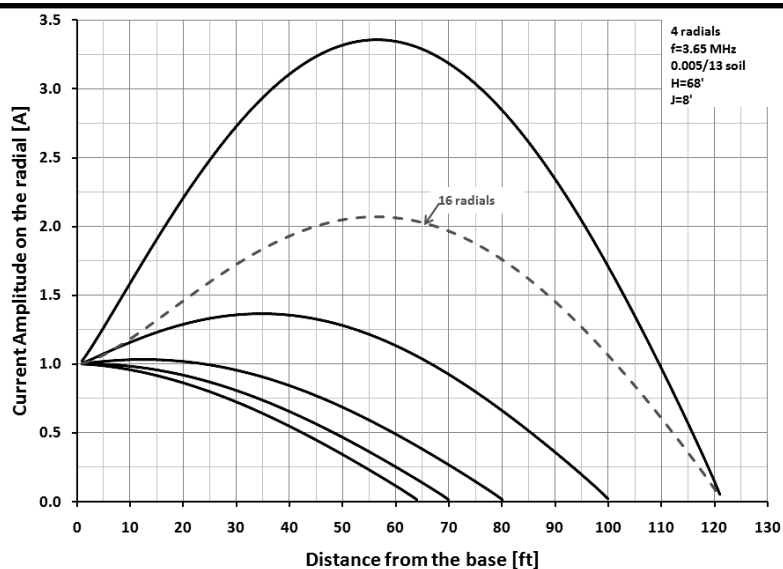

Figure 23 — Radial current distribution as a function of distance from the base. N = 4, H = 68 feet, f = 3.65 MHz, J = 8 feet and average soil.

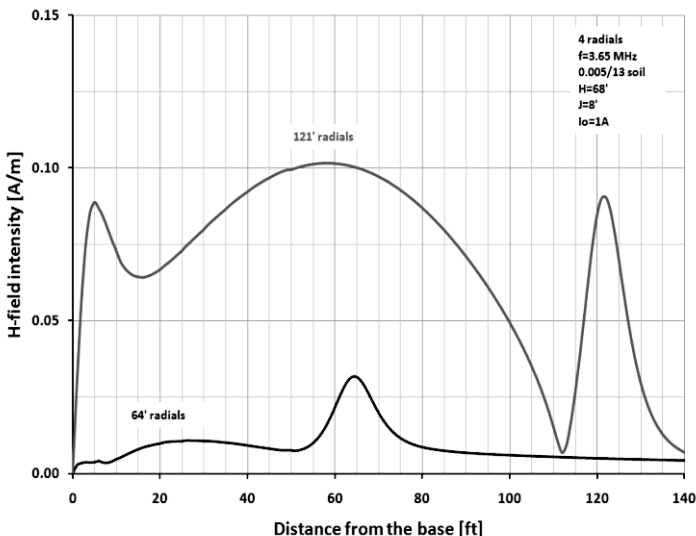
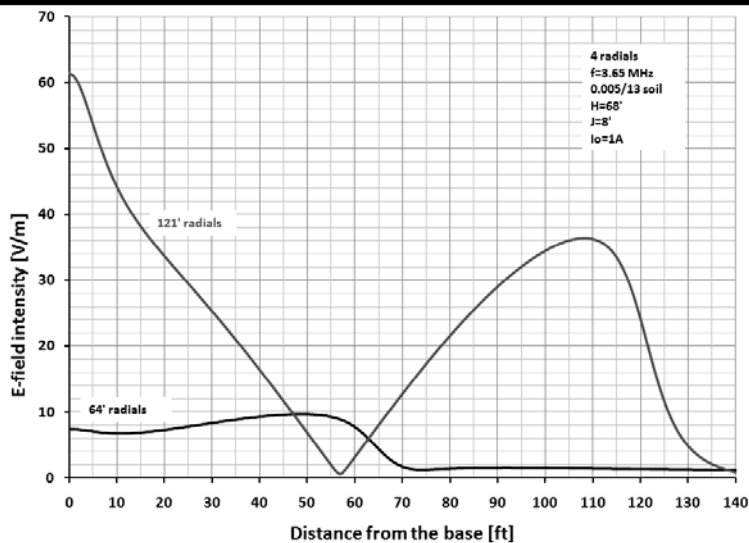

Figure 24 — E and H field intensities close to the ground surface directly below the radials with N = 4.

Part 3, *NCJ*, May/June 2005, pp 17-19.

³²Christman, Al, K3LC, "Compact Four-Squares," *NCJ*, vol 32, No. 4, Jul/Aug 2004, pp 10-12.

³³Christman, Al, K3LC, "Verticals by the Sea," Part 1, *NCJ*, July/August 2005, pp 9-12. Part 2, *NCJ*, September/October 2005, pp 4-6. Part 3, *NCJ*, November/December 2005, pp 17-20.

³⁴*Admiralty Handbook of Wireless Telegraphy, His Majesty's Stationary Office*, 1932, pg 799, Figure 452.

³⁵Burghard, George, "Station 1BCG," *QST*, February 1922, pp 29-33.

³⁶Kelley and Hudson, "Hams Span the Atlantic on Shortwave!" *QST*, December 1996, pp 28-30.

³⁷Ponte, Maurice, U.S. patent 2,026,652, "High Frequency Transmitter," 7 January 1936. French patent No. 764,473 (1933) and UK patent No. 414,296 (1934).

³⁸Brown and Epstein, "An Ultra-High Frequency Antenna of Simple Construction," *Communications*, July 1940, pp 3-5.

³⁹Belrose, John, VE2CV, "Vertical Monopoles with Elevated Radials: An Up-date," *10th International Conference on Antennas and Propagation*, April 1997, IEE conference publication #436, pp 1.190-1.195.

⁴⁰Severns, Rudy, N6LF, letter to *QST* Technical Correspondence, awaiting publication, but available at www.antennasbyn6lf.com.

⁴¹See www.4nec2.com.

⁴²Belrose, Jack, VE2CV, "Elevated Radial Wire Systems For Vertically Polarized Ground-Plane Type Antennas, Part 1-Monopoles," *Communications Quarterly*, Winter 1998, "Part 2-Phased arrays," *Communications Quarterly*, Spring 1998.

⁴³Weber, Dick, K5IU, private communication, July 2011.

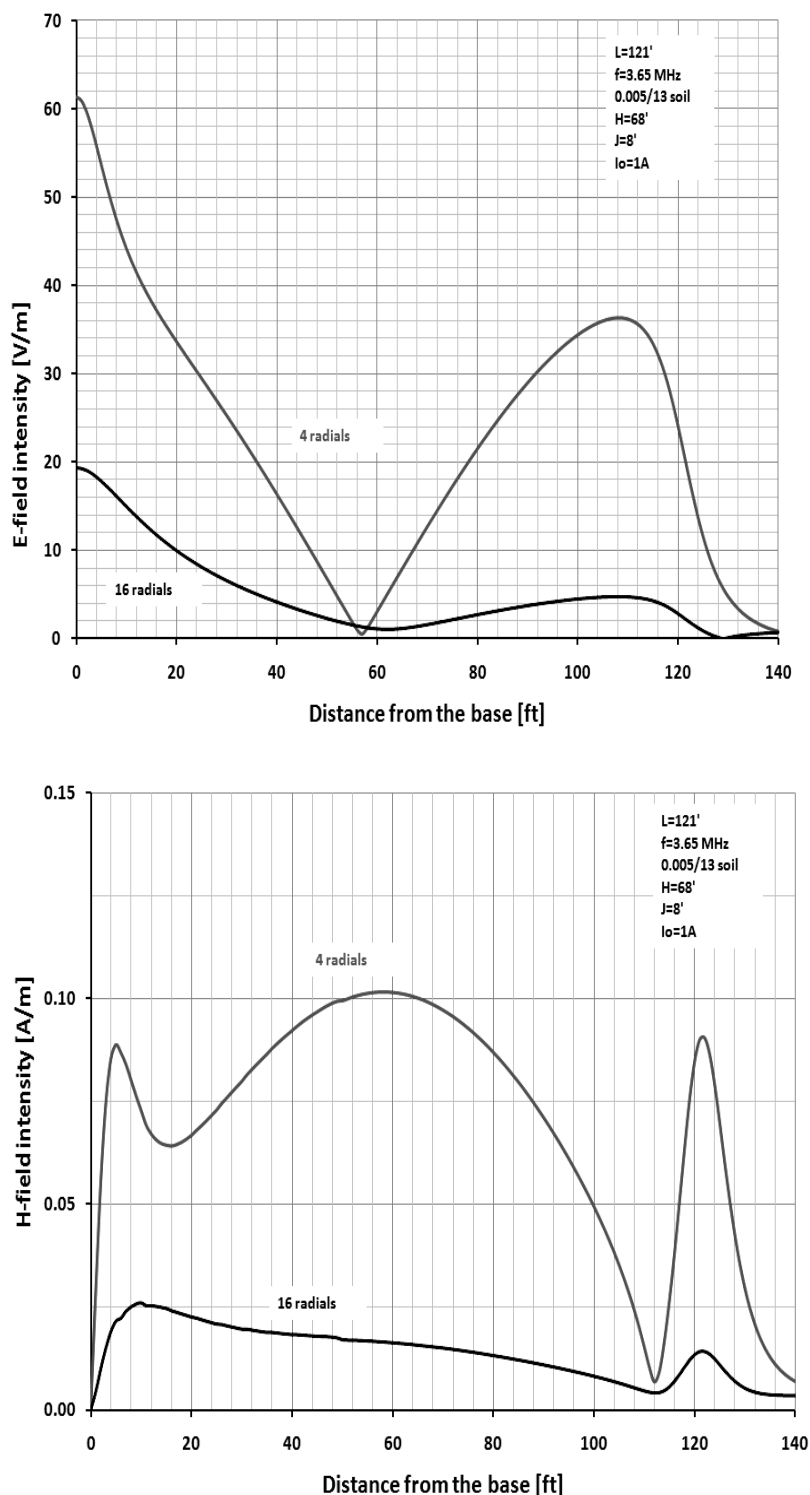

Figure 25 — E and H field intensities close to the ground surface directly below the radials. N = 4 and 16.

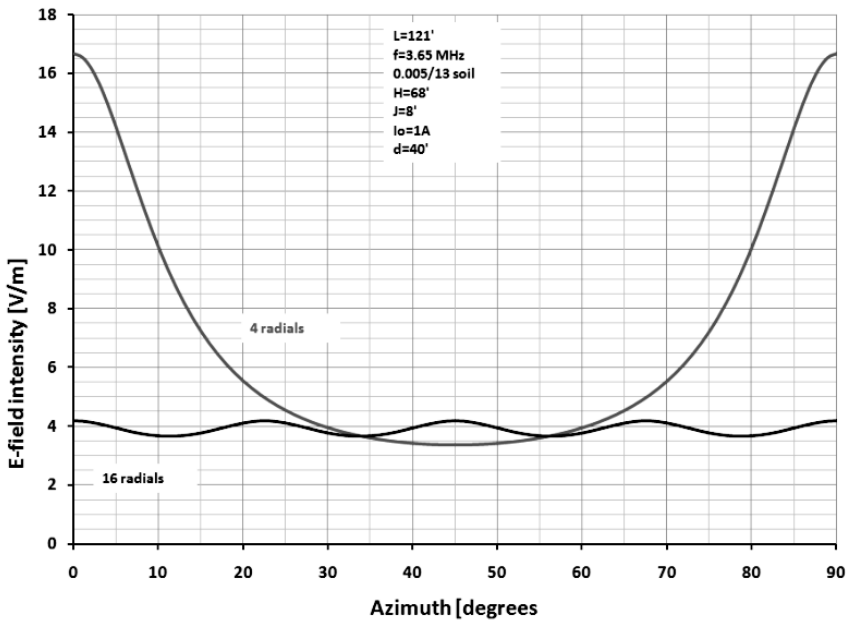
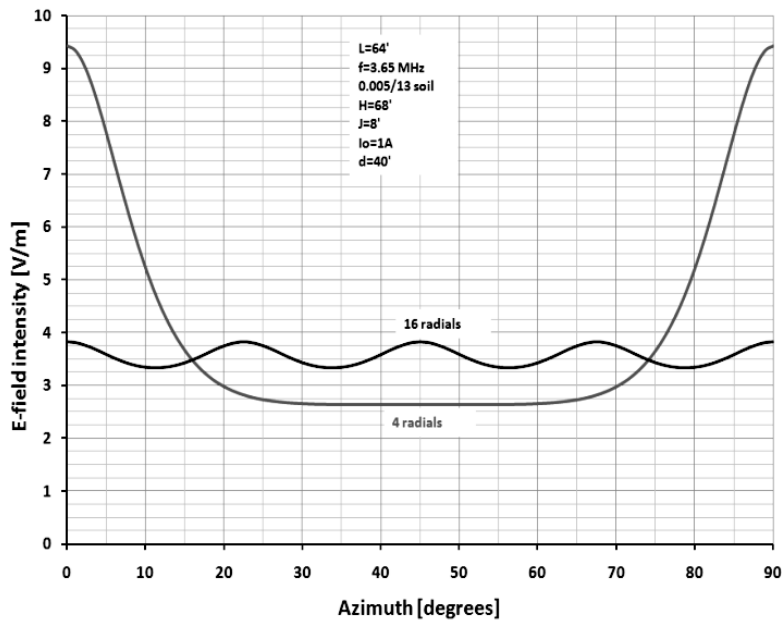

Figure 26 — E-field intensity just above ground on a 90° arc 40 feet from the base.

QEX