

Monster Quads

By Rudy Severns, N6LF
PO Box 589
Cottage Grove, OR 97424



Quads are fascinating antennas. I've been afflicted with the desire to build them for over 40 years. The first one was a two-element job I built while serving with the Army in Germany (DL4ND/DL4SFG) in the 1950s. To this day I'm not sure how I managed to shinny up a 70-foot pole to install the quad, but I was determined to get it working! And work it did!

True madness did not come upon me until I read Lindsay's 1968 article on quads.¹ I promptly built a six-element 20-meter monster (on a 60-foot boom) using the dimensions in the article. While I was at it, I added six elements on 15 meters and 11 elements on 10 meters. During initial testing using a small exciter (about 10 W) the first contact was the Russian Antarctic station, long path. After that I was hooked—and it's been all downhill from there!

If you live in an area where heavy icing is a regular occurrence, this article should be saved for April 1st. At my present QTH in western Oregon we seldom have ice storms. The most severe in the past ten years put about 1/2 inch of ice on my quad. The distortion was alarming but no permanent damage occurred. More ice than that, however, would start to break things. Perhaps it is possible to build quads to stand up to heavy icing, but I doubt it is worth the trouble for antennas of the monster size discussed in this article.

The antennas I describe are large and require significant time, effort and money to implement. The point of this article is to give you some useful ideas and perhaps some inspiration. I have included the dimensions, performance predictions, many mechanical details and some of the mistakes I made along the way. You can, of course, replicate any of these antennas directly but you will get better results if you consider them a starting point and then design an

So you're dreaming about a really big antenna for 40 meters? N6LF tells us about his monster two-element 40-meter quad, with bonus three elements on 20 and 15 meters.

antenna to meet your own particular needs and preferences.

Modeling

Good *NEC-2* and *NEC-4*-based software is now available and is a worthwhile investment for a project of this size. Quads are generally lower-Q antennas than comparable Yagis and therefore somewhat less sensitive to dimensional variations, supporting structures and interlaced multi-band elements. But you will still find the best results can be had only by modeling the complete structure and designing for your particular needs.

I did all my modeling for this article using *GNEC-4*, which is *NEC 4.1*-based.² I modeled the WØHTH six-element quad in free space, while my 40/20/15-meter multi-band quad is centered at 100 feet, over average ground ($\epsilon = 13$, $\sigma = 0.005$ S/m) using the Sommerfeld ground model.

While there is remarkably little interaction between elements of different bands, you must take some care to prevent unexpected resonances due to the matching sections and the open-circuited feed lines on those driven elements not in use. I fed each driven element separately and led the feedline to a multi-pole coax relay mounted

at the center of the boom. I used the modeling program to select lengths of feedline that did not result in any spurious resonances that would upset the performance on another band. This was not very difficult, but required some attention.

WØHTH Quad

Just for old time's sake. I went back and took a look at the multi-element quad I built in 1968 to Lindsay's dimensions (see **Table 1**). In those days I didn't have a computer on my desk to do antenna modeling, so I just relied on his information. The results had been great, but I was curious to see how modern modeling would compare with Lindsay's experimental work. Based on his

Table 1
Dimensions of 20-Meter WØHTH Six-Element Quad

Element	Location (ft)	1/4 Length (ft)
Reflector	0	18.04
Driven	12	17.60
Director 1	24	17.28
Director 2	36	17.28
Director 3	48	17.28
Director 4	60	17.32

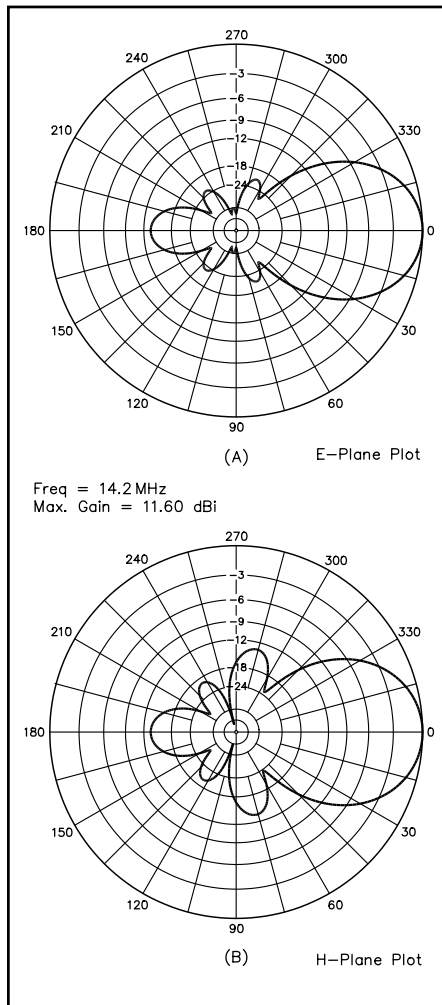

Fig 1—W0HTH 6 element 20-meter quad, free-space radiation patterns. At A, E-plane pattern and at B, H-plane pattern.

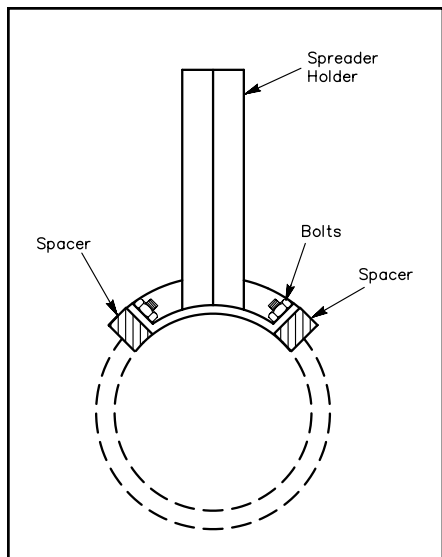

Fig 2—A method for accommodating a larger boom diameter for a spreader hub.

experimental work at 440 MHz, scaled down to 14.2 MHz, Lindsay predicted a forward gain of 13.4 dBi. It is hard to tell exactly what the F/B ratio is from Figure III-3A in his article but it looks to be roughly 15 to 20 dB.

With *NEC-4.1* software the predicted pattern is shown in Fig 1. I computed a forward gain of 12.1 dBi and a F/B of 14 dB. This was not too bad, but I suspect that these numbers could be improved with a bit of fiddling with the model. I remember that I adjusted the reflector length slightly for maximum F/B when I built the antenna, and the F/B was quite good.

For 15 meters I scaled the 20-meter element dimensions (retaining the same element spacing) and then adjusted the reflector for maximum F/B and the driven element for resonance. On 10 meters I again scaled the dimensions and adjusted the reflector, but in the true ham spirit of “If a little is good, more should be lots better,” I added five more directors. I spaced each 10-meter element by 6 feet.

I made my boom from two 30-foot lengths of 4-inch-OD irrigation pipe. Most commercial spreader hubs are designed for 3-inch, not 4-inch, diameter booms, so to accommodate the larger boom, I placed spacer blocks

between the hub sections. See Fig 2. This worked well for hubs made from four separate pieces. However, some commercial hubs have one-piece castings and can't be expanded like this. To match to 50-Ω feedline I used $\lambda/4$ 75-Ω transmission line sections on each band.

With an 11-element quad on a 60-foot boom, I noticed some interesting propagation effects on 10 meters. On several occasions the band dropped out during a transcontinental QSO, with signal strengths dropping from S9+ to just above the noise level. Nonetheless, we were able to continue the QSO for an extended period of time, when for all intents and purposes the band was dead. There is nothing like a big antenna!

A Two-Element 40-Meter, Three-Element 20 and 15-Meter Quad

In 1989 I built another quad based on Lindsay's article. It had five elements on 20 and 15 meters—and nine elements on 10 meters—on a 50-foot boom. I did not yet have antenna modeling software so again I just used Lindsay's dimensions. The antenna worked very well but it also provided me with a lesson on wind loading and wind strengths on mountaintops in Oregon. The antenna itself stood up very well, but my

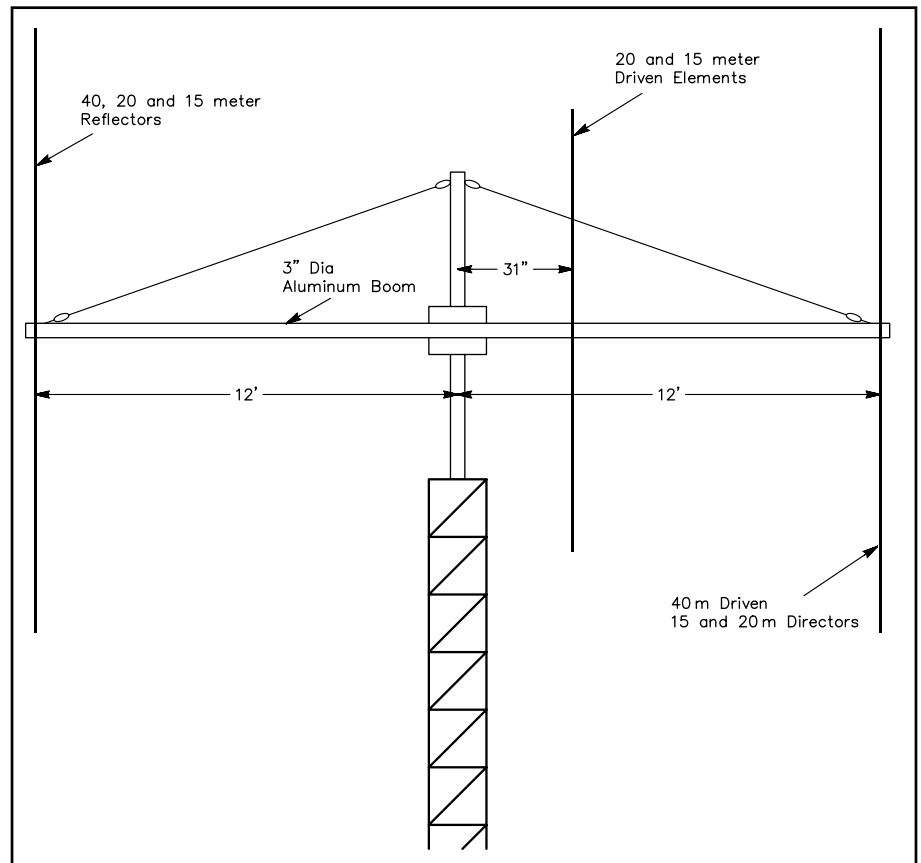

Fig 3—N6LF three-band quad dimensions: two elements on 40 meters; three on 20 and 15 meters.

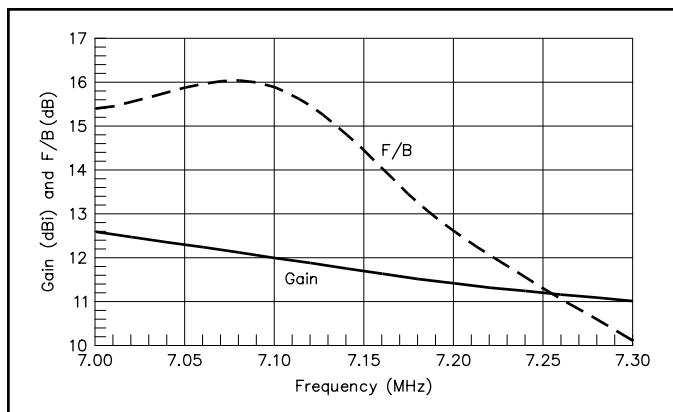

Fig 4—Gain and F/B characteristics on 40 meters.

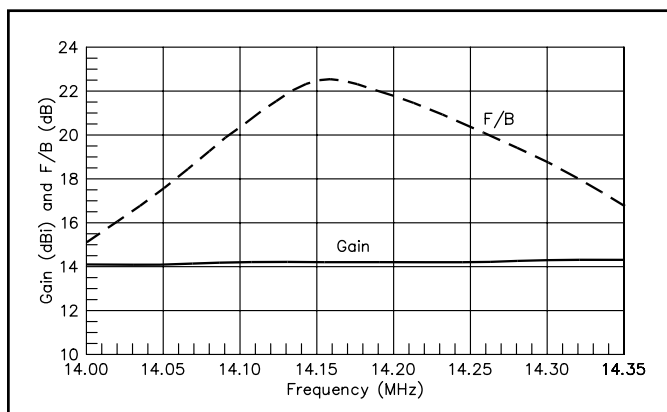

Fig 5—Gain and F/B characteristics on 20 meters.

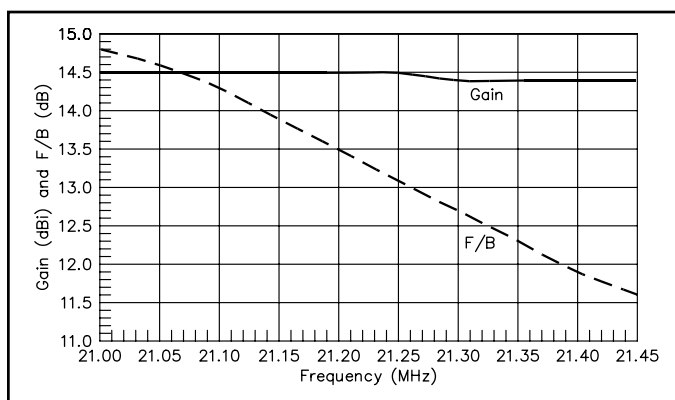

Fig 6—Gain and F/B characteristics on 15 meters.

Table 2

40, 20 and 15-Meter Quad Dimensions

Element	Location on Boom (ft)	1/4 Length (ft)	Spreader Length (ft)
40-meter Reflector	0	36.8	26.02
20-meter Reflector	0	18.4	13.01
15-meter Reflector	0	12.5	8.84
20-meter Driven	14.58	17.96	12.70
15-meter Driven	14.58	11.84	8.37
40-meter Driven	24	35	24.75
20-meter Director	24	17	12.02
15-meter Director	24	11.58	8.19

72-foot ungued tower collapsed in the first real storm that year. The antenna did not take kindly to this!

I replaced this system with a new tower and a monoband six-element 20-meter Yagi. The Yagi worked great but was only good for 20 meters. At that time the sunspot cycle was headed down the tube and it was clear that 40 meters was going to be a big-time DX band for the next several years. However, 20 meters was not going to go away, and there would be some openings on 15 meters even at a sunspot low. So I began to think about a new multi-band quad with full-size 40-meter elements and good performance on 20 meters.

Of course 40-meter elements are twice as long as the 20-meter elements I was accustomed to, so it was pretty intimidating. The wingspan is over 50 feet! I found a source for the spreaders and the hub hardware,³ and I now had good modeling software to design the antenna, so I went ahead with the project. The antenna has been up since 1993 with no real problems. It has proven to be durable, practical and a very good performer. It is a real killer on 40 meters. **Fig 3**, along with **Table 2**, gives the dimensions and element arrangement of the antenna.

The predicted gains and front-to-back (F/B) ratios for the three bands are given in **Figs 4 to 6**. The 40-meter band is wide enough that it is very difficult to obtain high gain and high F/B over the entire band with a simple two-element array. I chose to emphasize the CW end of the band, and this can be seen in Fig 4. I could have moved everything up in frequency and improved the phone-band performance but that would have meant a poorer F/B in the CW band. In my design, the F/B peaks at 16 dB and is above 15 dB over the entire CW part of the band. The gain peaks just outside the lower band edge and I could have traded a bit of F/B for a little more gain. The old rule that you can't have peak gain and peak F/B at the same frequency definitely applies.

The 20-meter performance is very good. In this case I chose to optimize at roughly midband; Fig 5 shows a minimum F/B of 15 dB over the entire band, with a peak F/B of greater than 22 dB. The gain is also very flat over the entire band. Overall, this is a very nice compromise for a three-element array.

This is a good point to go back to Fig 3 and discuss the choice of boom length and element placement. Normally a two-ele-

ment array has a boom length of 0.12 to 0.15λ for best performance. That would have resulted in a 16 to 20-foot boom for 40 meters. However, even at a sunspot low 20 meters is still a workhorse DX band and I wanted to have a really good three-element array on that band. Thus I made the boom a few feet longer to improve the 20-meter performance. The result on 40 meters was to slightly reduce the gain and F/B, but the longer boom had the advantage of presenting an approximately $112\text{-}\Omega$ feed-point impedance. This could be easily matched with a $75\text{-}\Omega$ (RG-11) $\lambda/4$ -matching section. The greater spacing also broadbanded the antenna somewhat on 40 meters, which in the end more than compensated for the lower peak gain and F/B.

If you look closely at Fig 3 you will see something unusual. Because the elements in a three-element quad extend well below the boom, the middle element must be moved off center to stay well clear of the tower. In most designs the driven element is moved closer to the reflector. In my case, however, I went the other way because I felt it gave me a better set of compromises. The 20 and 15-meter driven elements are closer to the director. This gave me very nice perfor-

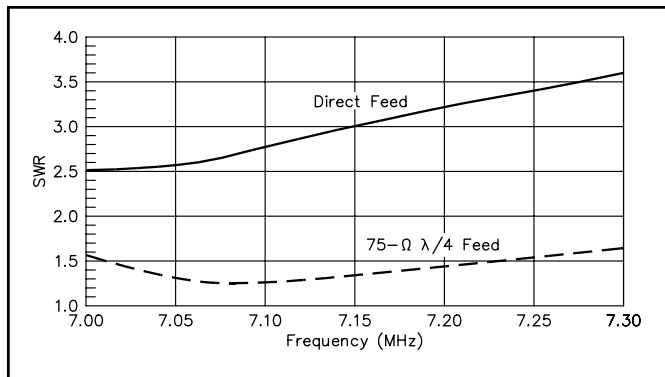

Fig 7—Solid line shows 40-meter 50-Ω SWR with direct feed. The dashed line shows the 40-meter 50-Ω SWR using a quarter-wave 75-Ω matching section.

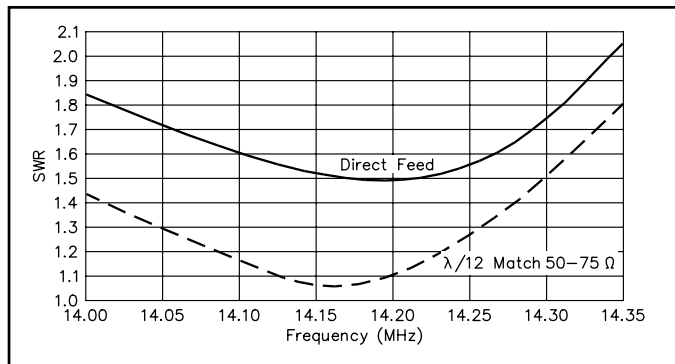

Fig 8—Solid line shows 20-meter 50-Ω SWR with direct feed. Dashed line shows 20-meter 50-Ω SWR with a 50 + 75-Ω series transformer.

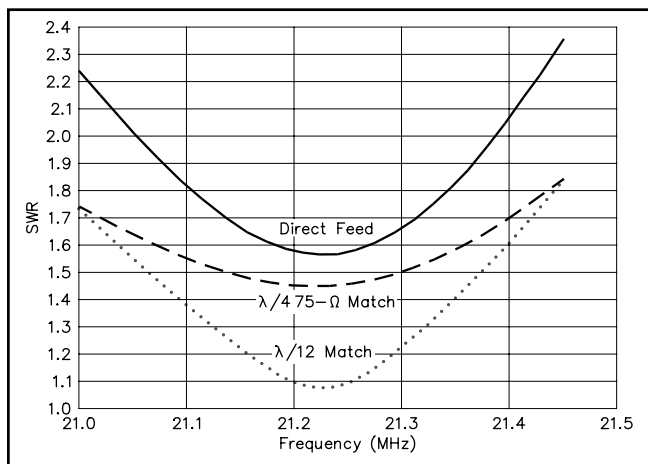

Fig 9—Solid line shows 15-meter 50-Ω SWR with direct feed. Dashed line shows 15-meter 50-Ω SWR with quarter-wave 75-Ω matching section. Dotted line shows 15-meter 50-Ω SWR with a series transformer match.

mance on 20 meters but compromised the F/B on 15 meters. Since I did not expect 15 meters to be a primary DX band during the sunspot minimum I accepted this. This reduced 15-meter performance is shown in Fig 6. The gain is good and very stable over the entire band but the peak F/B is low. I have again deliberately emphasized the CW end of the band just from personal preference.

Figs 7, 8 and 9 show the SWR performance for several matching choices. On 40 meters, if you do no matching, the SWR will be unacceptable (solid line in Fig 7). By adding a $\lambda/4$ -matching section of 75-Ω line the match is very good over the entire band, as is shown by the dashed line in Fig 7.

On 20 meters you do not have to use a matching section, since the SWR is less than 2:1 over all but the uppermost portion of the band (solid line in Fig 8). However, because I have a nearly 200-foot run of cable, every little bit of loss hurts. I used a twelfth-wave or series-section transformer using 50-Ω (RG-213) and 75-Ω (RG-11) sections.^{4,5} The result is shown in Fig 8 as the dashed line.

On 15 meters there are several possible choices. The solid line in Fig 9 shows the SWR for no matching. It is acceptable over most of the band but not at the band edges,

especially considering my long feed line. The dashed line in Fig 9 illustrates the effect of a $\lambda/4$ 75-Ω matching section and the dotted line in Fig 9C shows the effect of a $\lambda/12$ matching section. The $\lambda/12$ match is better near midband but about the same as the $\lambda/4$ section at the band edges. I chose to go with the slightly simpler $\lambda/4$ section.

The forgoing discussion illustrates some of the design trade-offs that you must make. It is for this reason I suggested earlier that these designs are more for inspiration than exact replication. You must decide for yourself what the trade-offs should be.

Just for the curious, because of the harmonic relationship between 15 and 40 meters, the 40-meter antenna has a low SWR on 15 meters and can even be operated on that band. There is some gain but the F/B is essentially 0 dB.

Some Mechanical Details

The support hub for the 20/15-meter driven elements was a standard commercial cast-aluminum piece made for 20-meter quads. These hubs are, however, totally inadequate for a 40-meter quad. **Fig 10** is a sketch of the welded hub assemblies (two each) I used for the 40-meter spreaders.

These hubs are made from 3/8-inch aluminum plate. I obtained these from the same source as the long spreaders but you could fabricate them yourself.³

Wire! A big quad uses a lot of wire. Over the years I have used many different kinds of wire for the elements, ranging from copper house wire, solid Copperweld and stranded Copperweld. In an antenna this large the wire is a key structural element and it must have considerable strength in order to give years of service. Solid or even stranded pure copper wire is unsatisfactory, mainly due to rapid work-hardening from the constant motion of the spreaders as the wind blows. For this antenna I used #13 AWG stranded copperclad steel wire with high-density polyethylene insulation.⁶ For some time I used an uninsulated version of this wire but even though I live in a rural area with no pollution, acid rain or salt atmosphere, I found that the wire still corroded. This potentially could weaken the wire and might increase losses. The insulated wire is more than strong enough and shows very little sign of corrosion even after several years. The wire size is also large enough to keep the losses acceptable (≈ 0.2 dB, according to the model).

When I first built this antenna I made some basic errors in the boom diameter and wall thickness, and in the guying (or the lack thereof). When I took down the 20-meter Yagi, I used two sections of that boom for the new quad. The boom tubing was 3 inches in diameter with quite thin walls (≈ 0.060 inch) and I used only a single support guy to each end, as shown in Fig 3. That was not good enough—after a couple of windstorms the boom started to bend sideways. No doubt some better engineering up-front would have told me that!

If you want to use 3-inch thin-wall tubing you must use side guys. There is simply too much mass and wind loading, even though the lever arm is only 12 feet long. Besides side guying, another approach would be to use larger-diameter tubing with a heavier

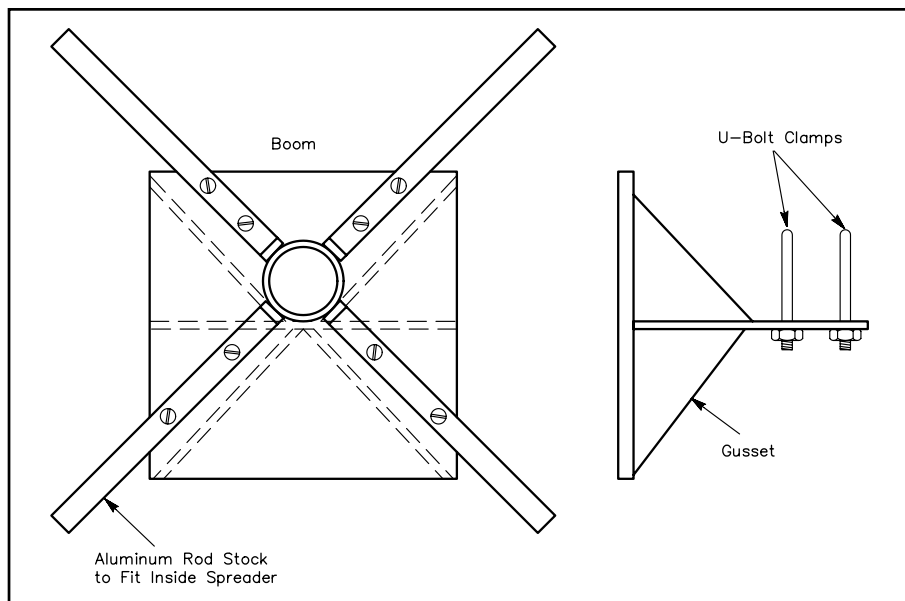

Fig 10—40-meter spreader hub design.

wall. For antennas larger than this example you will certainly have to do both. Since designing this antenna I have obtained copies of Leeson's book⁷ as well as articles by Weber⁸ and Bonney⁹ on the mechanical design of large arrays. These have shown me the error of my ways and I strongly recommend you read them for any new design.

The spreaders for a 40-meter quad are twice as long as the 20-meter ones. They are also much heavier—3 to 5 times heavier. In my past experience with 20-meter quads the droop in the spreaders was very small and I used only a light wire jumper across the corners to keep the wire from sliding through the corner holder. In this antenna the stress on this wire was much higher and one jumper promptly broke, allowing the wire to slide through the corner mounting devices. This in turn allowed the spreaders to droop. The result was distortion in the shape of the loop like that shown in Fig 11. The shape is more like a trapezoid than a square. At first I thought this was no big deal but a quick check showed the F/B had practically disappeared at the low end of the band.

Modeling the "new" shape showed that in fact the peak F/B had moved up to the high end of the band and the gain was degraded. The lesson is: Solidly anchor the corners of the elements to the spreaders. Realize that there will be a substantial load on this anchor due to the dead weight of the spreaders and the wind loading.

A commercial spreader hub for 20-meter and higher frequency quads usually resembles the one shown in Fig 2. While they are generally pretty reliable, I wanted something more rugged. What I did was to use two hubs, facing each other, trapping the

spreader ends between the two faces of the hubs. The result is a much stronger anchor at the base of the spreaders.

Any large array requires a first-class rotator. I have been using an Orion OR-2300 rotator. It has given me more than a little heartburn, but then again I did have practically the first one sold. The manufacturers have been very responsive to problems and I believe the latest version (OR-2800) is a first-class rotator. The average ham rotator won't cut it in this league. With the large mass of the 40-meter spreaders and the heavy-duty hubs at the ends of the array, the moment of inertia is large.

Once you get the array rotating, the rotator has to bring it to a halt again. This can result in high stress on the rotator and also on the top of the tower itself. I can see the whole top of my tower twisting a bit as the rotator applies the brakes. To protect everything I have adopted the policy of using a low rotator speed for small angular changes. For a large change in direction I use a faster speed initially but then slow it down with the speed control as I approach the desired heading.

After the collapse of my old tower I installed an 89-foot motor-driven telescoping model. You can believe I am now a fanatic about keeping the tower down except while actually using it. I don't think the insurance company would be nearly so nice a second time. If a particularly severe storm is expected I will often throw a line over the boom and lash it down to ease the strain on the rotator.

More Madness

Because the present antenna has survived

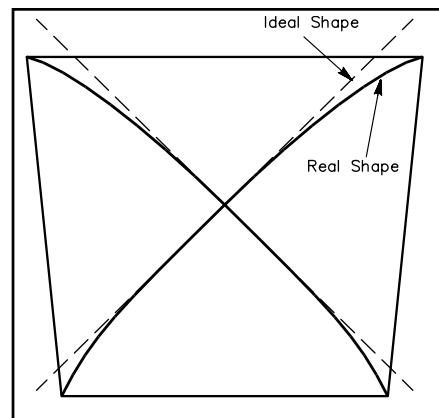

Fig 11—Distortion due to the weight of the spreaders when not anchored at the corners.

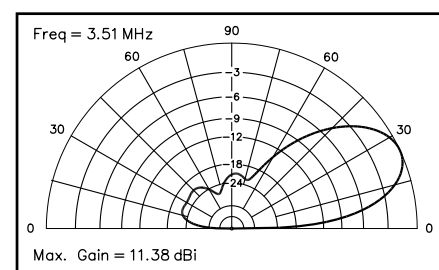

Fig A—80-meter quad elevation pattern at 3.51 MHz, at 100 feet above flat, average ground, including losses in the copper wire elements and $Q = 250$ inductor loading.

many years of hard use, it's obviously too small. I am in the process of designing a new antenna, now that the sunspots are back. (By the way do you know how you can tell that Shakespeare was a 160-meter man? Who else would say, "Out, out, damned spot"?)

The new antenna will have three elements on 40 meters, five elements on 15 meters and nine elements on 10 meters. Four of the 10-meter elements will be Yagi-style dipoles, because for single-band elements they are simpler mechanically (not to mention the fact that I have a 10-meter Yagi I can cannibalize). The tentative boom length is 50 feet, which is reasonable in the light of my earlier work. I may also include elements for the 30, 17 and 12-meter bands but that is still to be determined. Perhaps this will be a topic for *The ARRL Antenna Compendium, Vol 7*.

The ultimate madness is on the drawing boards also. A full-size two-element 75/80-meter quad. I intend to tune this behemoth to cover the entire band with a simple relay scheme. See the sidebar for a brief description. Stay tuned for the next installment—coming to you as soon as I can get leave from the asylum!

The Ultimate Insanity

As shown in Ref 11, it is possible to build a full-size, rotary, two-element quad for 75/80 meters. There are two problems to be solved: First, how to tune it remotely so that I can have good performance in at least the two DX windows (3.510 and 3.790 MHz) or better yet, over larger sections of the band. Second, how to solve the mechanical problems imposed by the need for spreaders nearly 50 feet long and boom more than 50 feet long.

Bandspreading the antenna is not just a matter of an acceptable SWR. You also need to keep the gain and F/B as near peak values as possible. If you are going to all the trouble to build this monster there is no reason to compromise! I expect that I'll design the basic quad for the higher end of the band, say 3.850 or 3.790 MHz and then use relays to add in a small amount of inductive loading in both the reflector and the driven elements. If the elements are already near full size then the amount of loading will be small and will introduce very little loss. Of course, the inductors must still be designed for high Q. I will try to optimize the antenna at 3.790 MHz with the loading inductances shorted out with relays and then open the relays for 3.510 MHz operation.

Table A shows the typical dimensions for such an antenna, on a 44-foot boom at 100 feet above average ground. The elevation radiation pattern at 3.510 MHz is given in **Fig A**. Note that the effect of wire and inductor losses are included in this model. In the right location this would be a dominating antenna. By adjusting the loading inductances, this kind of performance could be available at any point in the band.

Because it is not necessary that the entire length of the spreader be insulated, 40-meter fiberglass spreaders could be extended with 2-inch-OD aluminum tubing. In effect, the hub would have a 44+ foot diameter. Modeling work indicates that this large a mass of metal inside the perimeter of the antenna would have little effect on the performance, so long as the longer support guys are broken up with insulators. I'd probably make the support guys from Kevlar or other insulating material.

The hub is designed along the lines of a bicycle wheel and shown conceptually in **Fig B**. Note that Fig B is only for the hub, the fiberglass spreaders are mounted on the ends of the hub arms. Two of these hubs, one on each end of the boom, would be needed. Obviously the boom will have to be guyed to support the weight.

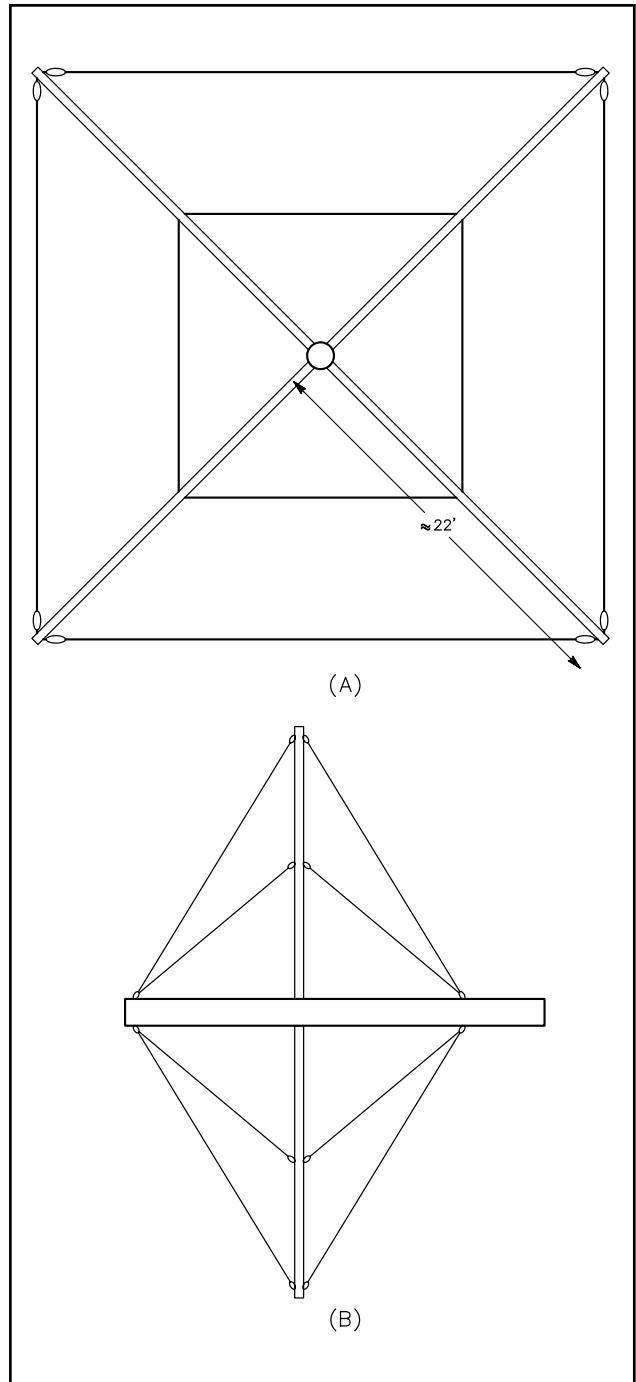

Fig B—80-meter quad conceptual spreader-hub design.

Table A
75/80-Meter Quad Dimensions

Element	$\frac{1}{4}$ Length (ft)	$\frac{1}{2}$ Diagonal (ft)
Driven Element	65.4	47
Reflector	68.2	49

References

- J. Lindsay, Jr, W0HHTH, "Quads and Yagis," *QST*, May 1968, pp 11-19, 150.
- GNEC-4*, Nittany Scientific, Inc, Hollister, CA 95023, 408-634-0573.
- Lightning Bolt Antennas, RD 2 Rte 19, Volant, PA 16156, 724-530-7396.
- The ARRL Antenna Book*, 18th Edition (Newington: ARRL, 1997), pp 26-4, 26-5.
- D. Emerson, AA7FV, "Try a Twelfth-Wave Transformer," *QST*, Jun 1997, pp 43-44.
- The Wireman, Inc, 261 Pittman Road, Landrum, SC 29356, 803-895-4195.
- D. Leeson, W6NL (ex-W6QHS) *Physical Design of Yagi Antennas* (Newington: ARRL, 1992).
- D. Weber, K5IU, "Determination of Yagi Wind Loads Using the Cross-Flow Principle," *Communications Quarterly*, Spring 1993.
- S. Bonney, K5PB, "Practical Application of Wind-Load Standards to Yagi Antennas: Part 1," *QEX*, Jan/Feb 1999, pp 46-50.
- Another source for quad parts: The Antenna Mart, PO Box 699, Loganville, GA 30249, 770-466-4353.
- J. Devoldere, *Antennas and Techniques for Low-Band DXing*, 2nd Edition (Newington: 1994), Chap 13, Sec. 4.